

# *New England 4-H Horse Show Rules and Guidelines*

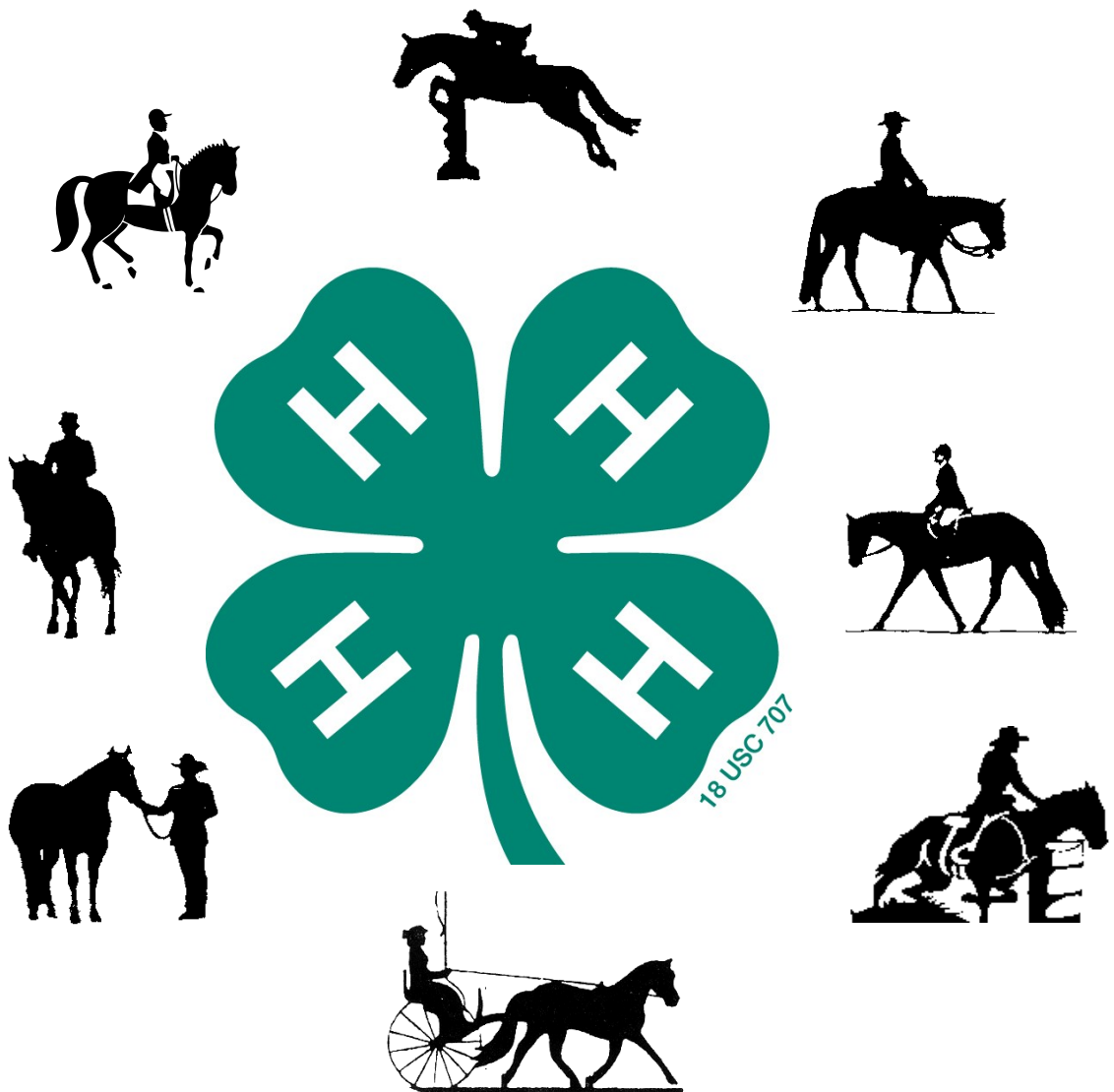

Basic guide to local, county, and state/regional 4-H Horse shows as well as for those classes in open shows limited to 4-H membership entry. This rules manual is for organizers, officials, exhibitors, parents and judges.

**Revised January 2007**

## Committee Responsible for 2004 Revisions

**Sherri Thornton, Chair\***  
New England 4-H Horse Program Chair  
16 Johnson Flat Road  
Burnham, ME 04922

**Carol Birdsey\***  
New England 4-H Horse Program  
Committee  
2 Randolph Road  
Middletown, CT 06457

**Anne Blizniak\***  
New England 4-H Horse Program  
Committee  
139 East Street  
Hadley, MA 01035-9791

**Mary Fay\***  
New England 4-H Horse Program  
Committee  
601 Main Street, Room 202A  
Burlington, VT 05401

**Judy Forsyth\***  
New England 4-H Horse Program  
Committee  
72 Maple Street  
Center Barnstead, NH 03225

**Diane Martin\***  
New England 4-H Horse Program  
Committee  
168 Woodville-Alton Road  
Hope Valley, RI 02832

**Dr. Jennifer Nadeau\***  
Connecticut Extension Equine Specialist  
Department of Animal Science  
University of Connecticut  
U4040 3636 Horsebarn Road Extension  
Storrs, CT 06269-4040

\*Committee members at time of printing.

### **Committee responsible for 2007 revisions:**

**Sherri Thornton, Chair; Carol Birdsey, Emily Alger, Anne Blizniak, Mary Fay, Debbie Danforth, Judy Forsyth, Chesley Chumura, Lisa LeDoux, Karen Snyder, Kate Slattery**

**If accommodations are needed to participate in an event, please contact the event manager in writing at least 4 weeks in advance of the event.**

Prepared by:  
Cheryl LeFebvre, Secretary  
Robert Bartlett, Work study Student  
University of Vermont  
State 4-H Office

## TABLE OF CONTENTS

Introduction	page 4
Objectives	page 4
Use of Name and Emblem of 4-H	page 6
Judges	page 6
Show Personnel and Responsibilities	page 7
Eligibility	page 10
General Rules	page 11
Safety Precautions	page 12
Danish System/Ribbons	page 13
4-H Fitting and Showmanship	page 13
Side Saddle Division	page 16
Saddle Seat Equitation, Road Hack, Pleasure, Performance	page 17
Hunt Seat Division, Equitation, Pleasure, Hunter Under Saddle, and Equitation Over Fences	page 19
Hunter Division, Hunter over Fences, Hunter Hack	page 23
Western Division, Equitation, Pleasure, Western Riding	page 26
Western Riding Patterns	page 30
Western Reining	page 32
Western Reining Patterns	page 35
Western Handiness	page 39
Miscellaneous Classes: Trail, Command, Versatility, 4-H Project Class, 4-H Club Class	page 41
Miniature Horse Classes	page 44
Driving Classes: Miniature, Draft Horse, Reinsmanship, Pleasure Driving, Handiness, Obstacle Driving	page 44
Dressage Division	page 44
Gymkhana Division	page 46
Sample Forms (may be copied) (Part 2 of rulebook)	page 53

**Items in regular print are rules that need to be followed in each state.**

*Items in italics are guidelines that may vary from state to state.*

## Introduction

These rules have been developed to serve as a basic guide for local, county, and state/regional 4-H horse shows as well as for those classes in open shows limited to 4-H membership entry. This manual is for organizers, officials, exhibitors, and parents. The purpose is to assure uniformity in organization, judging criteria and procedure throughout New England. There is no intent in the publication of these rules to suggest that all classes listed should be held at any show, nor is any limitation implied of shows to only those classes listed. It is suggested that 4-H shows adapt these rules to govern the operation of these shows. It is recognized, however, that a show committee might wish to modify these recommendations to suit their particular needs. When using this guide, you will find that it includes three types of statements:

1. Rules and procedures that must be followed. (**These will be in regular print**)
2. Suggested policies for situations that may be variable.
3. Guidelines that serve to aid in planning and executing horse events.
4. State specifics may vary. (*These will be in italics*)

The 4-H Horse Show places the major emphasis on the accomplishments and development of the member. Because the economic background of 4-H members varies widely, the quality of the horse is not directly related to the member's abilities. Under saddle classes should be judged on manners, suitability, and performance with minimum emphasis on conformation.

**First and foremost, all exhibitors will conduct themselves as young ladies and gentlemen. Politeness and good sportsmanship are mandatory – no exceptions. Parents will be expected to conduct themselves in such a manner as to set a good example for the 4-H exhibitor and other spectators at the show.**

When youth are assigned to the appropriate horse show class, and the youth with disabilities are appropriately supported, participating youth can compete on a level playing field.

This rulebook has been set up by 4-H programs in neighboring states to try to unify showing procedures and rules as much as possible. In doing so, safety, good taste and establishment of a good public image are paramount. 4-H is a youth development program. Any specific rule not found in this rulebook will then default to the current USEF rulebook and that rule will apply.

With publication of this manual it is assumed that all 4-H shows will be run in accordance with these rules and guidelines unless exceptions are noted in the class list.

## Objectives For The New England 4-H Horse Show

### Help 4-H Club Members

- To develop personal traits which will enable them to become more effective citizens and assume roles in leadership.
- To develop teamwork and sportsmanship.
- To become aware of opportunities within the horse industry.

- To learn and better understand new developments and methods in agriculture as related to the horse industry.
- To obtain wholesome competitive experience on a broader level above and beyond those available in the individual counties.
- To exhibit animals they have cared for in project work over an extended period.

### **Objectives:**

The objectives of the 4-H Horse Activity are:

1. To create public awareness of opportunities in the 4-H Horse Activity
2. To encourage 4-H Youth to emphasize the educational aspect of 4-H
3. To encourage adoption of uniform educational standards in the 4-H Horse Activity throughout New England
4. To recognize the 4-H members for achievement with the 4-H Horse Activity

### **Expectations of Ethics**

It is understood that all exhibitors, parents, leaders, trainers, coaches, spectators or anyone else on the horse show grounds will adhere to the following expectations:

1. Be worthy of trust, honor and confidence.
2. Respect all people, including myself.
3. Be responsible, accountable and self-disciplined in the pursuit of excellence.
4. Be just, fair, and open.
5. Be caring in my relationships with others.
6. Be aware that my actions and decisions affect others and strive to be a contributing and law-abiding citizen.

### **Dress Code and Program Content Expectations**

In 4-H, in everything we do, we are role models for youth of all ages. Therefore, we have high expectations that 4-H members, leaders, and volunteers will abide by certain dress codes and program content expectations.

Dress Code attire for individual classes will be addressed within the guidelines.

1. All clothing should be neat, clean, and appropriate for activity.
2. The entire torso must be covered with no navels showing.
3. Hair should be neatly combed and appropriately contained.
4. Any graphics, or printing on any clothing, which is considered obscene or offensive, is unacceptable.

Program Content/presentation – our participants and spectators at these activities include youth of all ages, therefore:

1. Lyrics, costumes, signs, dialogue and other program content should support positive 4-H/youth developments.
2. The use or display of weapons is discouraged.
3. Violence will not be promoted.
4. Sexually explicit material and foul language will not be included.
5. Content will not be degrading to any population.

## **Use of the Name and Emblem of 4-H**

The use of the name and emblem of the 4-H is regulated by federal law. This law states that only activities or programs under supervision of Cooperative Extension may use the name and emblem of the 4-H club work. Any district, area, or state 4-H horse show must have approval of the State 4-H Office. Local, representative county, regional, and state 4-H Shows or events sponsored by other organizations or individuals and shows which do provide separate classes for 4-H members are not permitted to use the name and emblem of 4-H without approval of appropriate Extension offices.

## **The 4-H Show**

A 4-H horse show **MUST** be conducted by a 4-H horse club or group of 4-H horse clubs, or member delegates from 4-H horse clubs/councils at the local, county, regional, or state levels.

- A. There are two types of 4-H Horse Shows
  1. The 4-H Horse Show:
    - a. Limited to 4-H members only.
    - b. May be divided into divisions.
  2. The 4-H sponsored Open Horse Show
    - a. Is open to the public.
    - b. Should offer 4-H divisions and classes.
- B. *In a 4-H Horse show or a 4-H division at an Open Horse Show, Fitting and Showmanship classes should be offered.*
- C. Any non 4-H affiliated show intending to offer 4-H classes must contact the state 4-H office and follow procedure as directed by that office.

## **Judges**

1. Judges will be competent, well-qualified adult individuals, whose names appear on the New England 4-H Horse Judges List. Judges may also be selected from the USEF judges list; New England Horseman's Council, local horse councils, breed judge's lists, or referrals from established horse show management.
2. The judge must place each class in accordance with the rules and class specifications of this handbook.
3. The decision of the judge is final.
4. An exhibitor does not have the right to inspect the judge's cards. However, an exhibitor may request of the show committee or stewards the reason of the decision at a proper time and place. The show committee may request the judge to give his reasons. A judge is not to be approached with regard to any decision while judging or about to judge.
5. Spectators (anyone other than the show committee or exhibitors) will not question or visit with the judge.

6. Any questions from such individuals must be channeled through the show manager or steward.
7. Exhibitors will not argue with a judge.
8. If judges are expected to judge more than one division, be sure they are qualified in each division. Judges shall be knowledgeable of breed distinctions and shall judge classes accordingly.
9. The use of different judges each year is encouraged.
10. **Show management** shall instruct judges that major emphasis of 4-H classes is placed on the exhibitor's accomplishments, not the quality of the horse.

### **Judging**

1. Good judging depends upon the correct observance of horses and / or riders and the measuring of them against a standard commonly accepted as the ideal, according to the conditions of the class being judged. A judge serves three interests: his/her own conscience, the exhibitors, and the spectators. He/she should make clear to the audience that it is the best horse or riders in his/her opinion, who win. If the judge is unclear about something, he/she should feel free to ask the child or show superintendent about the situation. 4-H club work is a learning experience, and the members should be able to follow the judging procedure.
2. A judge must adjudicate each class in conformity with the rules and specifications of the class as they appear in the rulebook.
3. The decision of the judge is based solely on his/her individual preference.

## **SHOW PERSONNEL AND THEIR RESPONSIBILITIES**

### **Show Committee/Manager**

1. *The show committee will be responsible for the operation of the show. It will be the duty of this committee to enforce all rules as set forth in the rulebook.*
2. *The show committee will determine the requirements for any class that is not clearly defined in the manual and post the course, in cases where necessary, at least one hour before the scheduled time of class.*
3. *The show committee will eliminate, without waiting for protest to be made, any improper entrant of a horse or rider, after notifying entrant of error.*
4. *It is recommended that the show committee include in their show rules and conditions that proof of the exhibitor's age is required and must be available for inspection during the show. They must also insist that for a 4-H Show or a 4-H Class in an open show the exhibitor present the HORSE APPROVAL FORM for the respective state.*
5. *The show committee has the right to select a steward. A steward should clearly understand that he has no connection with the show committee or personal involvement with the judging of the show. He/she should point out in a diplomatic manner any instances where the rules*

*are not enforced. He/she should not dictate to the judges or the show committee, but should immediately report to the appropriate officials any violations of the rules, which might invalidate a class. He/she should keep him/herself available to judges, exhibitors, and the show committee at all times to clarify the application of 4-H horse rules and to investigate any situation where the rules are not upheld.*

6. *It is the responsibility of the show committee to provide a copy of this rulebook to the judge for his/her use two weeks prior to the event.*
7. *Show committees/judges are all responsible for noting any cases in which an entry poses a danger to other entrants. The judge may dismiss any entry that presents a risk to themselves or other entrants in the ring.*

**Secretary - Duties may include, but are not limited to:**

1. *Accepts entries, both before and during the show.*
2. *Reviews entries for completeness and accuracy, paying particular attention to date of birth of exhibitor for youth classes, and making sure entry fulfills all show rules.*
3. *Accepts entry fees and other related income.*
4. *Posts entries to individual classes to determine number of exhibitors in each class.*
5. *Prepares announcer list.*
6. *Prepares judge's cards.*
7. *Calculates Championship points from results on judge's cards.*
8. *Oversees distribution of ribbons and/or trophies.*
9. *Collects and submits bills for payment.*
10. *Prepares and presents financial report to Show Committee (see Organizers Information).*
11. *Answers procedural questions.*

**Steward**

1. May be the Show Committee or some other designated adult and should be selected from those with previous experience or from the USEF list.
  - a. Stewards must be familiar with the 4-H Horse Show Rule Book.
  - b. Stewards must be tactful, yet assured enough to enforce the rules.
  - c. Stewards should be willing to take the time to educate.
2. The steward is responsible for verifying the enforcement of rules as set forth by the 4-H Horse Show Rule Book and the show committee.
3. The current USEF Rule Book shall govern absence of a specific rule.
4. The steward should remain available to the judge, exhibitors and show committee at all times to clarify the application of the rules.
5. The steward should investigate any situation when rules are not upheld.
6. The steward is the one to be approached with questions, not the judge.
7. Formal protest must be in writing, accompanied by a fee as determined by the show committee and filed with the secretary before the end of the show. Protest fees will be refunded only if protest is upheld. In the event protest is not upheld, protest fee reverts to the show treasury.

### **Ringmaster**

1. *The ringmaster is in the ring with the judge, but is conscious not to block the judge's view of the competitors.*
2. *The ringmaster conveys the judge's directions to the announcer and competitors.*
3. *The ringmaster observes exhibitors and informs the judge if problems arise.*
4. *In the absence of a ribbon runner, ringmaster shall distribute ribbons and trophies in classes.*

### **Announcer** - *Shall move the show forward by announcing:*

1. *General information and rules as necessary.*
2. *Class and exhibitor information.*
3. *"On deck" status for the next class.*
4. *Awards.*
5. *Next class entering the ring.*
6. *Shall be concise and shall not monopolize the airwaves.*

### **Supervisors of Warm-up Area**

1. *MUST KEEP SAFETY ISSUES FOREMOST.*
2. *Must be an adult designated by the Show Committee.*
3. *Individuals not complying with the direction of the Warm-Up Supervisor will be reported to the Show Steward and may result in dismissal from the show.*

### **Other Show Personnel**

1. *Gate people*
2. *Recorder*
3. *Timer*
4. *Ribbon Runner (good use of members not exhibiting)*
5. *Food Booth Staff (good use of members not exhibiting)*

### **Emergency Personnel** (On location or on-Call)

1. *Veterinarian*
2. *Farrier*
3. *EMT*
4. *Ambulance*
5. *Police and Fire*

### **Rider/Age Divisions** (For 4-H purposes a riders age is as of January 1st)

1. *Lead line - For riders age 5 and older. Person leading must be at least 14 years of age. Not to be judged, all exhibitors receive participation awards.*
2. *Beginner/walk trot – 18 years and under – have never cantered/loped in any competition or on the grounds thereof, exhibitors over 12 should be in their first or second year of riding.*
3. *Advanced Beginner - 18 years and under – exhibitors may compete in Advanced Beginner one season or eight shows. Cantering/loping may be done briefly, individually, or in small groups.*
4. *Junior – 13 years and under*
5. *Senior – 14 years through 18 years*
6. *Adult - 19 years and older*

## **Eligibility of Members and Animals for 4-H Shows and Competitive Activities**

1. A member may carry more than one animal for his/her 4-H project. If this is the case, each animal must be listed on a HORSE APPROVAL FORM.
2. The member must present the 4-H Approval Form to the show secretary at each show before being allowed to participate in a 4-H horse show. It is mandatory to present this form for 4-H classes in open horse shows sponsored by organized horse clubs. Any horse listed on a horse approval form after April 1<sup>st</sup>, is not eligible for Eastern States Exposition.
3. Exhibitor must show his/her own projects. Project animals may be owned by the 4-H member, leased, loaned or shared.
4. To exhibit at the New England Regional 4-H Horse Show at Eastern States Exposition, the 4-H member must have been responsible for the animal by April 1<sup>st</sup> of the current year.
5. Horses **CANNOT** be leased, rented or borrowed from private or professional riding stables or owners for the sole purpose of showing.
6. Any type of equine may be used for a 4-H Horse Project. The animal should suit the size, skill and competency of the rider. The rider should be able to keep the animal under control at all times and manage him safely. When in the ring if this is not possible, horse and rider may be excused from the ring by the judge.
7. Horses two years of age or under as of January 1<sup>st</sup> of the current year cannot be shown in any under saddle classes.
8. **No youth exhibitor may show a stallion over one year of age.**
9. The administration of any drug to a horse shown in any 4-H class is strictly prohibited unless a veterinarian certificate verifying the soundness of the horse for use and the prescribed treatment/ medication is presented at registration.
10. Animals must be serviceably sound and healthy or they will be excused from the ring.
11. Horses that naturally perform at a lateral gate as opposed to a diagonal gait will be judged accordingly (i.e., Tennessee Walking Horse).
12. Animals that are known to kick must be marked by a red ribbon in the tail.
13. **Pony and Horse classes shall be designated according to the following:**
  - Western Pony.....14 hands and under*
  - Western Horse .....Over 14 hands*
  - English Pony.....14.2 hands and under*
  - English Horse .....Over 14.2 hands*

## **GENERAL RULES**

1. *No mechanical devices of any sort may be used during exercise period. Such devices may include, but are not limited to, tie-downs, draw reins, martingales (except for exercise over fences) and action enhancing boots or shackles. Protective leg boots, bell boots and polo wraps may be used during exercise. Any other equipment in question must be legal in the show ring in order to be used in exercise. See the show steward for questions.*
2. **The above rule will be enforced at Eastern States Exposition.**
3. Any treatment of a horse by anyone on the grounds, which may be considered cruel, abusive or unnecessary, is prohibited. The show committee/ steward may disqualify anyone mistreating an animal and ask him or her to leave the grounds. An official report may be filed with appropriate authorities.
4. All participants in any New England 4-H sponsored shows/activities are required to wear a properly fitted **equestrian helmet** which carries a current ASTM/SEI approval with secured chin harness properly fastened while riding or driving in designated schooling areas, the show ring, and while riding or driving anywhere on the competition grounds. This applies to all exhibitors 18 years of age or younger, including all 4-H exhibitors regardless of age.
5. It is the responsibility of the rider or the parent or guardian of the minor rider, to see to it that the headgear worn complies with such approved standards and carries the proper seals, and is properly fitted and in good condition. Due to degeneration concerns, equestrian and sport manufacturers recommend replacement every five years. The New England 4-H Council Horse Program, organizing committees, and licensed officials or leaders are not responsible for checking headgear worn for such compliance. The New England 4-H Horse Program or said committees and officials and leaders make no representation or warranty, expressed or implied, about such headgear and cautions rider that serious injury may result despite wearing headgear, as no helmet can protect against all foreseeable injuries in equestrian activities.
6. At any 4-H equestrian activity, the official activity manager (e.g., show manager, clinic organizer, club leader) may, at his/her discretion, check a participant's equestrian helmet for proper standards. If the participant is found to be wearing an unapproved, defective, or improperly fitted helmet, he/she will NOT be permitted to participate in any mounted or driving activities until proper headgear is acquired.
7. **4-H CLASSES ARE RESTRICTED TO ENROLLED 4-H MEMBERS ONLY** with their approved project animals.
8. In the absence of specific rules in this book, any question of policy shall be referred to the current USEF Rulebook.
9. The judge's decision will be final.
10. Classes may be cancelled, combined or divided at the discretion of the show committee.
11. *Every effort will be made to post patterns in a timely manner.*

12. Any questions concerning the rules should be referred to the show steward or the show committee to render a final decision.
13. *Judges may not ask exhibitor to switch horses in under saddle classes.*
14. **Every 4-H exhibitor, if they are under the age of 18, must have an adult on the grounds that will assume responsibility for him/her.**
15. *Horses are not allowed to be kept in or tied to trailers that are not attached to tow vehicles.*
16. 4-H exhibitors are to prepare and handle their own project animals to the extent of their ability. Common sense in regards to safety justifies assistance.
17. Fall of horse and or rider in any class will eliminate placement. A rider is considered to have fallen when they are separated from their mount in such a way as to necessitate remounting or vaulting into the saddle. A horse is considered to have fallen when the shoulder and haunch on the same side are touching the ground or an obstacle and ground.
18. Tack changes or holds should not be longer than three minutes. Time begins when the last horse in the previous class leaves the ring.
19. Any changes in the show schedule should be announced in the timeliest fashion possible.
20. Soundness of each horse is at the discretion of the judge. Obvious lameness shall be cause for disqualification. Obvious lameness is consistently observably at a trot under all circumstances; marked nodding; hitching or shortened stride; minimal weight bearing in motion and/or at rest; and inability to move.

### **Safety Precautions**

1. Helmets required, see page 11. In the interest of safety, there will be no penalty at 4-H Horse Shows for riders/drivers wearing protective headgear in lieu of traditional hats.
2. Horses should be confined to warm-up areas and prohibited from spectator and food areas.
3. Horses should be kept at a walk except in the warm-up area and show rings.
4. No dangerous obstacles will be used in trail or game classes.
5. Exhibitors are responsible for having their equipment in good repair.
6. Ring gates should be kept closed during all classes and competitions.
7. It is recommended that plastic or rubber cones be used for markers in reining patterns.
8. *Show management should require that dogs, other pets and small children be restrained at all times.*
9. Poles and other obstacles should be made of a safe material.

10. Limit the size of classes for safety (suggested maximum of 20). Consider size of ring and ability of riders.
11. Youth with documented disabilities will not be penalized for using special equipment or special assistance to perform a riding or fitting and showmanship class. Youth with documented disabilities may receive accommodations in the form of modified testing.

**Health Precautions for Horse Shows and Events**

*Show committees or management may require a health statement from a veterinarian stating that the animal is sound and free from communicable diseases, to be presented upon registration at a show or event. All equines must be vaccinated for rabies and a verification of this must accompany the animal to all events. A negative Coggins MUST accompany all horses dated appropriate to locale of show. It is recommended that all horses be properly immunized.*

Please check with show committee for required health documentation.

**Danish System**

Using the Danish System, all exhibitors receive ribbons. Blue ribbons denote excellent, red ribbons denote good, and white or yellow ribbons denote fair.

All blue ribbons should be numbered (or placed) i.e., 1<sup>st</sup> blue, 2<sup>nd</sup> blue, etc. Red and white/yellow ribbons will not be in any particular order.

**Ribbon Awards-American System**

1 <sup>st</sup> : Blue	2 <sup>nd</sup> : Red	3 <sup>rd</sup> : Yellow	4 <sup>th</sup> : White	5 <sup>th</sup> : Pink
6 <sup>th</sup> : Green	7 <sup>th</sup> : Purple	8 <sup>th</sup> : Brown	9 <sup>th</sup> : Grey	10 <sup>th</sup> : Light Blue

**4-H Fitting & Showmanship**

The purpose of the 4-H Horse Fitting and Showmanship program is to encourage 4-H'ers to maintain high standards of horse management and responsibility toward 4-H projects. A fit horse reflects continuous care and is not accomplished overnight.

**General Rules**

1. Exhibitor must be a 4-H horse project member with Horse Project Approval Form on file in the 4-H Extension Office.
2. All members should prepare their own project animal to the extent of their ability.
3. In 4-H Fitting and Showmanship classes, it is the exhibitors' efforts which are judged, NOT the breed type or conformation of the horse.
4. All 4-H Fitting and Showmanship classes must be judged according to the Summary of Uniform Scorecard Fitting and Showmanship contests.
5. There are two different forms of Fitting and Showmanship classes which can be offered:
  - (a) Traditional, with one judge, or
  - (b) Station, with two judges.

- a. Traditional: One judge who judges both the fitting and the showmanship portions of the class.
- b. Station: The **Showmanship Judge** scores the showmanship aspect of the entry. The **Fitting Judge** scores the appearance of the exhibitor and fitness of the entry.

**SUMMARY OF UNIFORM SCORECARD FOR 4-H HORSE SHOW  
FITTING AND SHOWMANSHIP CONTEST**

**APPEARANCE OF ANIMAL**

**Total Points.....40**

**1. Condition (15 Points)**

- a. The animal should be useably sound, have sufficient flesh, a smooth coat, and firm muscles.

**2. Grooming (15 Points)**

- a. Coat should be clean and free of stains. Hairdressing, hoof preparation and powder, if used, should be neatly and sparingly applied.
- b. Mane and tail should be clean and free of tangles and dandruff.
- c. Hooves should be trimmed and shaped. If shod, shoes must fit and not show undue wear. Clinches should be smooth. Hoof preparation is permitted, but not required.

**3. Trimming, Braiding, and Banding (5 Points)**

- a. Excess hair should be clipped or trimmed from the legs, fetlocks and around the ears and muzzle. The interior of the ears may be clipped, but no penalty shall result from unclipped ears provided excess or protruding hairs have been removed. The head should be made as attractive as possible by trimming excess or long hairs with special emphasis under the jaw and in the “bridle path” area. Clipped areas will appear smoother if trimming is done 3-4 days prior to a show. Trim according to breed resemblance. Horse may be totally clipped or not, as exhibitor wishes.
- b. Braiding or banding, if used, should be neat and suitable for type of horse. Miniature horses should not be braided or banded.

**4. Tack (5 Points)**

Weanlings and yearlings must be shown in a halter to protect the mouth for future biting. Miniature horses are shown in a halter. Western horses shall be shown in a halter. English horses shall be shown in a bridle. Tack should be clean, supple, neat and fit properly.

**APPEARANCE OF EXHIBITOR**

**Total Points.....10**

1. Exhibitor shall present a neat and clean appearance and be attired in riding clothes appropriate to their seat. Boots with heels are required.
2. Exhibitors showing Miniature Horses must wear a long sleeved shirt, gloves, and boots, but need not to be attired in riding clothes.
3. Gum chewing will be penalized.

**SHOWING ANIMAL IN THE RING**

**Total Points.....50**

**1. Leading (15 Points)**

- a. For traditional Fitting and Showmanship, the exhibitor should enter leading the animal at an alert walk around the ring in a counter-clockwise direction. Reins or lead strap must be held in the right hand 4-12 inches from the bit or halter. The remaining portion of the rein or strap must be held in the left hand in a safe manner. For station judging, the exhibitor must enter the ring according to the judge's directions.
- b. Animal should lead readily and walk and trot. This should be done briskly as the judge directs with the animal's head carried at a height appropriate to the type or use of horse. If working individually, the animal should move on a straight line away from and back to the judge unless otherwise directed.
- c. When making a turn, the horse should be turned to the right with the exhibitor walking around the horse. The ideal turn consists of the horse pivoting on the right hind leg while stepping across and in front of the right front leg with the left front leg. An exhibitor should not be penalized if their horse performs a pivot on the left hind leg, but an exhibitor whose horse performs the pivot correctly should receive more credits. A pull turn of 90 degrees or less is acceptable.
- d. Exhibitors must never crowd other exhibitors. When behind another animal, exhibitors must maintain a horse's length apart (8-10 feet). When lined up side by side, exhibitors must allow a safe distance between animals.
- e. When changing position in line:
  1. Exhibitors must lead the animal straightforward far enough so as not to disturb the horse on either side of them before making a turn.
  2. Exhibitors must return to the line by moving around the end of the line and leading forward either to their original position or to the place directed by the judge.
  3. Exhibitors must avoid leading their animal between the judge and the animal he is observing. Exhibitors must never stand between horse and judge.
- f. Using the Quarter System, the exhibitor is expected to move from side to side as the judge moves about in front, back, and alongside of the horse, always giving the judge an unrestricted view. The judge and exhibitor must always be in adjoining quarters (see below).

<u>Judge is in</u>	<u>Exhibitor should be in</u>
1	4
2	1
3	4
4	1

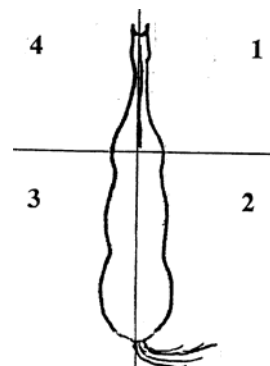

## 2. Posing (15 Points)

- a. When posing their animal, exhibitors must stand toward the front facing the horse, but always in relation to the position of the judge.
- b. The horse is posed according to type and use (i.e., the American saddle horse) in the show, posing with feet slightly spread and head up, and the Hunter with the head in a natural position, feet squared, but one hind foot may be slightly in advance of the other.
- c. When posed, exhibitors must try to keep their animal still. They may support their horse with their hand on his opposite shoulder when the judge picks up a foot or attempts to

- push him off balance. Exhibitors must always regain their position quickly and without fuss.
- d. When the judge is observing other animals, exhibitors should stand quietly if posed reasonably well.
  - e. Exhibitors must do most of the showing with the reins or lead strap, never kicking their horses' legs into position. Proper use of hands, voice or whip is accepted.
  - f. When working individually, exhibitors should pose the animal to the judge's directions. Never stand between your horse and the judge. The judge should have an unobstructed view of the animal.
  - g. Exhibitors must show their animal at all times, not themselves. Over showing, undue fussing and maneuvering are objectionable.

**3. Showing Animal to Best Advantage (10 Points)**

- a. Exhibitors must quickly recognize any conformation faults of the animal they are showing, and show it to overcome these faults.

**4. Poise, Alertness and Attitude (10 Points)**

- a. Exhibitors must keep an eye on their animal and be aware of the position of the judge at all times. They must not be distracted by persons and things outside of the ring.
- b. Exhibitors must respond rapidly to all requests from the judge and officials.
- c. Exhibitors must be courteous and sportsmanlike at all times.
- d. Exhibitors must keep showing until the entire class has been judged or excused.

**CLASS DIVISIONS**

**SIDE SADDLE**

**Appointments**

Side Saddle shall be permitted in any class. ASTM/SEI helmets required. Saddle and bridle must be for the same seat ridden. Clothing and appointments should be neat, clean and appropriate for the seat ridden for the show ring. See the International Side-Saddle Organization for specific regulations.

**General Sidesaddle**

Sidesaddle riders will be permitted in all classes. They will be subject to all class rules and requirements. The rider should be aware that placing might be affected if the judge is unfamiliar with sidesaddle.

**Tack/Equipment**

Appropriate sidesaddles must be used for English and Western classes. All other tack will be specified in class rules.

## **SADDLE SEAT DIVISION**

### **Appointments**

Conservative, well-coordinated, well-fitted clothing is preferred, they must be neat and clean. Special clothing is not to be given preference.

1. Minimum Requirements: Saddle seat pants, Jodhpur boots, shirt, tie, derby or soft hat for showmanship, ASTM-SEI helmet for mounted classes.
2. Preferred requirements: Saddle suit, jacket, gloves, and whip.
3. Optional requirements – spurs of unroweled type, **with a strap.**

### **Tack/Equipment**

1. All tack should be in clean, safe, serviceable condition for the horse and the rider.
2. Flat English type saddle – i.e.: Lane Fox or cutback with leather lining preferred. Forward Seat or dressage type saddles, or knee rolls are prohibited.
3. Entries will be shown in full bridles, although Pelhams are accepted.
4. Not Allowed: Forward Seat (Hunter type) Saddle, martingales or similar tie-downs, any type of curb strap or chain not permitted by USEF, any artificial appliances, “gingered” tails, wired ears, bandages, boots of any type, and ankle chains.
5. Not to affect judge’s decision: Extended feet, weighted shoes, set tail.

## **SADDLE SEAT EQUITATION**

### **Judging/Scoring**

Emphasis in this class will be placed on the rider’s ability to effectively control his/her horse and maintain his/her basic position while doing so. To be judged 90% on the rider’s positions, use of aids and cues, and control of horse and 10% on personal appointments and tack. The scoring of personal appointments and tack will be based on neatness of clothing rather than newness or expense, and cleanliness, condition and adjustment of tack.

Judged on seat, hands, and suitability of horse to the rider and the performance of the horse as it reflects the riding skill of the exhibitor.

### **Class Routine**

To be shown both directions of the ring at a walk, trot and canter. All riders may be required to execute any appropriate tests. Judges shall choose tests from the following list, or bring one of their own choosing, that are appropriate to the caliber of the class. The same test or tests shall be required of all riders chosen for this additional performance.

1. Drop and pick up the reins
2. Back, not more than 8 steps
3. Performance on the rail
4. Performance around the ring
5. Figure eight at a trot; demonstrating change of diagonals.
6. Figure eight at a canter on the correct lead – demonstrating a simple change of lead.
7. Serpentine at a trot demonstrating change of diagonal
8. Change of leads down center of ring demonstrating the simple change of leads. Judge to specify exact lead changes to be executed as well as starting lead.
9. Ride without stirrups – at any gait, no longer than 1 minute at the trot.
10. Dismount and mount.

### **Disqualifications**

At the judge's discretion, a rider MAY be disqualified for any of the following reasons:

1. Behavior of the horse or the rider, which might endanger themselves or other horses, and riders in the class.
2. Evidence of poor sportsmanship on the part of the rider.
3. Any treatment of the horse by its rider, which the judge deems cruel, abusive, and unnecessary.
4. Use of tack or equipment, which is prohibited.
5. Lack of sufficient control of the horse by its rider.
6. Fall of the horse and/or rider.

### **ROAD HACK**

#### **Appointments**

Exhibitors entering classes listed in this division must meet appointment requirements in either the Saddle Seat Division or Hunt Seat Division. Exhibitors shall not combine appointments from the two divisions (e.g. saddle seat clothing and hunt seat tack, etc.)

#### **Class Routine**

To be shown both directions of the ring at a flat-footed walk, trot, extended trot, canter and hand gallop on a reasonably loose rein. Horses may be asked to back. Horses may be asked to pull up at a halt from a hand gallop. Class may be split to hand gallop.

#### **Judging/Scoring**

Judged on (1) Performance, (2) Obedience, (3) Consistency, (4) Manners, (5) Suitability, in that order. Horses should lengthen stride. Excessive speed will be penalized. Horses should stand quietly and back readily.

### **Disqualifications**

See Saddle Seat Equitation.

### **SADDLE SEAT PLEASURE**

#### **Class Routine**

To be shown both ways of the ring at a walk, trot and a canter on a reasonably loose rein without loss of contact. Horses may be asked to extend the trot. Entries must be asked to back the horse. The horse should not back with excessive speed.

#### **Judging/Scoring**

Class to be judged on manners, performance and suitability of the horse as a pleasure mount. The smoothness, obedience and consistency of the performance will be considered rather than brilliance and animation

## **SADDLE SEAT PERFORMANCE**

### **Class Routine**

1. Horses are to be shown at a walk, park trot and canter both ways of the ring. The park horse should display brilliance and animation in his/her performance along with proficiency in executing the required gaits. Horses should stand quietly and back readily.
2. All horses will enter the ring in a counterclockwise direction until otherwise directed by the judge. To be shown both ways of the ring at the walk, park trot and canter.
3. All horses will be brought to a flat-footed walk before changing gaits.
4. After all the horses have been worked as specified in number 1; the judge may excuse contestants not to be further considered in this class.
5. The judge may ask for additional rail work from any of the remaining entries.

### **Judging/Scoring**

Emphasis will be placed on the horse's suitability as a park horse as evidenced by the brilliance, animation, and performance. Scoring will be based on performance and manners.

### **Disqualifications**

Refer to Saddle Seat Equitation.

## **HUNT SEAT DIVISION**

Braiding is traditional, but not required.

All jump heights are at the discretion of the show committee.

### **Appointments**

#### **Minimum Requirements**

1. Appropriate heeled boots (hunt or jodhpur).
2. Breeches or jodhpurs.
3. Shirt.
4. ASTM/SEI Helmet.

#### **Preferred Requirements**

1. Hunt Coat of conservative color.
2. Choker or tie.
3. Gloves.

#### **Optional:**

1. Spurs of unroweled type, with a strap.
2. Crops.
3. Half chaps are acceptable.

#### **Tack/Equipment**

Saddles of hunt or balance type preferred.

Regulation snaffles recommended or Pelhams with Cavesson nosebands and flat curb chain or straps. Kimberwicks and uxeter bits are allowed. A judge, at his/her own discretion, may penalize horses with non-conventional types of bits and nosebands.

Martingales are optional in classes over fences; they are prohibited in classes not to jump. Any change of equipment during a class may be penalized at the discretion of the judge. Dropped, flash or figure eight nosebands are not permitted in any class under the hunt seat division.

### **Judging/Scoring**

Same general basis of scoring will be used as for Hunt Seat Equitation. Safety of the riders' jumping style will be considered.

### **Disqualifications**

See Saddle Seat Equitation and #4 above.

## **HUNT SEAT EQUITATION**

### **Class Routine**

1. All horses will enter turning to the right in a counterclockwise direction until the judge otherwise directs them. To be shown both ways of the ring at a walk, trot and canter. Light contact with the horse's mouth is required. All horses will be called to line up for close inspection.
2. After all horses have been worked as specified in number 1, the judge may then dismiss any contestants not being further considered in the class.
3. The judge may continue to work the remaining contestants as already described in number 1, or he/she may ask any of the remaining contestants to execute an appropriate test of their riding skill. Suggested tests from which the judge might choose include:
  - a. Back.
  - b. Halt from a canter
  - c. Figure eight at a trot, demonstrating change of diagonals. At left diagonal, rider should be sitting in the saddle when the left front leg is on the ground; at right diagonal, the rider should be sitting in the saddle when right front leg is on the ground. When circling clockwise at a trot, rider should be on the left diagonal, when circling counterclockwise, rider should be on the right diagonal.
  - d. Figure eight at canter on correct lead demonstrating simple change of lead (this is a change whereby the horse is brought back into a walk or trot and restarted into a canter on the opposite lead). Figure commenced in center of two circles so that one lead change is done).
  - e. Ride without stirrups.
  - f. Dismount and mount.
  - g. Figure eight at canter on correct lead demonstrating a flying change of lead.
  - h. Change leads down center of ring demonstrating simple lead change.
  - i. Execute serpentine at a trot and/or canter on correct diagonal or lead demonstrating simple or flying change of lead. A series of left and right half circles off center of imaginary line where correct diagonal or lead must be shown.

- j. Walk from a hand gallop.
- k. Canter on counter lead.
- l. Half turn on forehand and/or a half turn on haunches.
- m. Answer questions about horse – tack or equitation.

### **Judging/Scoring**

Class to be judged on seat, hands, suitability of horse to rider, and the performance of the horse as it reflects the riding skill of the exhibitor. To be judged 90% on the rider's position, use of aids and cues, and control of the horse, and 10% on personal appointments and tack. The scoring of personal appointments and tack will be based on neatness of clothing rather than newness or expense, and cleanliness, condition and adjustment of tack.

### **Disqualifications**

See Saddle Seat Equitation Section.

## **HUNT SEAT PLEASURE**

### **Class Routine**

All horses will enter the ring in a counter-clockwise direction until the judge otherwise directs them. They are to be shown at the walk, trot and canter both ways of the ring. Horses will be asked to back. The pleasure horse should be easy to handle, obedient, and consistent.

1. After all entered have been worked, the judge may then excuse contestants not to be further considered in the class.
2. The judge may ask for additional rail work from remaining entries.

### **Judging/Scoring**

To be judged on the suitability of the horse as a pleasure mount, manners and performance. The smoothness, obedience and consistency of the performance will be considered rather than the brilliance and animation.

### **Disqualification**

Refer to Saddle Seat Equitation.

## **HUNTER UNDER SADDLE**

### **Class Routine**

Horses are to be shown at walk, trot, canter, and hand gallop both ways of the ring. The judge may ask for extended trot. The Hunter Under Saddle should be obedient, alert, responsive, and move freely with a ground-covering gait.

1. All contestants will enter the ring in a counter clockwise direction until the judge otherwise directs them. All exhibitors will be asked to hand gallop in groups of not more than eight to ten at one time. May be asked to back.
2. After all horses have worked, the judge may then dismiss any horse not to be further considered in this class.
3. The judge may continue to work the remaining horses.
4. At the hand gallop, the judge may ask the group to halt and stand on a free rein (loose rein).

### **Judging/Scoring**

To be judged on the suitability of the horse for this style of riding, manners, control, and smoothness of the performance on the flat.

### **Disqualifications**

Refer to Saddle Seat Equitation.

## **HUNT SEAT EQUITATION OVER FENCES**

### **Tack/Equipment**

Same as that for Hunt Seat Equitation except that the use of martingales is allowed. Dropped nosebands and running martingales may not be used in conjunction with any curb action bit.

### **Class Routine**

The rider should demonstrate his/her ability in controlling the horse while going over fences such that a balanced, even pace is maintained while also maintaining a safe and suitable position.

1. The class will be held over at least six reasonable jumps.
2. The performance begins when the horse enters the ring or is given the signal to proceed after entering the ring. Except for refusals, jumping faults of the horse are not to be considered unless it is the result of the rider's ability.
3. Ticks and rails down shall not be scored in an equitation class over fences unless the fault of bad horsemanship. However, failure to complete a specified course of jumping fences in the wrong order shall be scored as "off course and the rider shall be eliminated".
4. Any or all contestants may be called back to perform a walk, trot, canter or execute any appropriate test of skill included in class requirements for Hunt Seat Equitation, or any of the following:
  - a. Jump low fences at trot.
  - b. Pull up between fences at trot, except in a combination.
  - c. Jump fences on a figure eight course.
  - d. Jump Serpentine course, showing change of lead.

## In-Gate Diagram

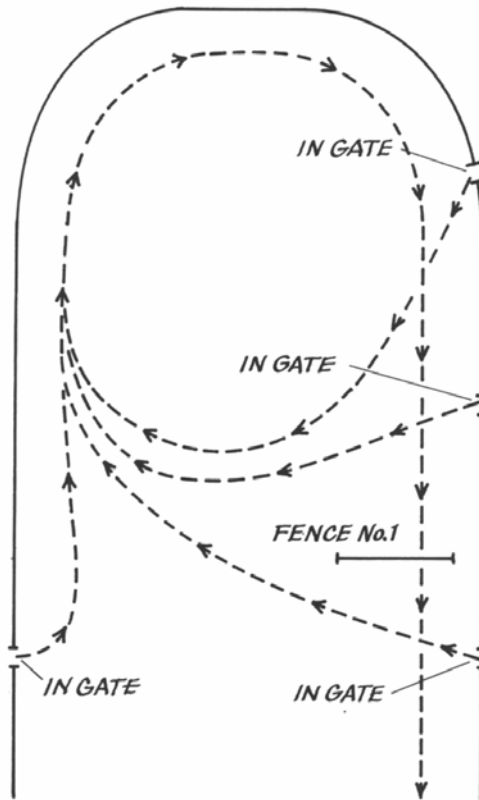

Circling in either an Equitation Class Over Fences or a Performance Class Over Fences: Only one circle is allowed before fence #1. The size of the circle depends on the length and width of the ring. However, a circle of 100 feet diameter is the maximum allowed with fence #1 included in its circumference (see diagram). The circle may commence at a sitting or posting trot (correct diagonal) with a transition to a canter at least 5 strides before fence #1. Thereafter, a canter (unless the judge specifies otherwise) MUST be maintained. Once the exhibitor has commenced a circle, it must be continued. Incorrect, misshapen circles or failure to maintain a specified gait shall be scored as a refusal.

## HUNTER DIVISION

### Class Routine

The hunter should provide his rider with a safe, consistent ride at a working pace over a course of fences similar to those that might be encountered in the field. This requires that all horses must be serviceably sound and any horse showing evidence of lameness, broken wind or impairment of vision will be refused an award and will be excused from the ring by the steward, show veterinarian, or judge.

Each horse will individually negotiate a course consisting of at least 8 jumps over a minimum of 4 different obstacles. At least one change of direction is recommended. The course diagram must be posted at least 1 hour before the class is called. The course must meet the approval of the judge.

## **Jumps and Obstacles**

1. Jumps shall be at least 10' in width (may include wings that are at least 22" wide). They should have a substantial appearance. Rails shall be at least 3" in diameter.
2. A variety of obstacles are encouraged – using coops, gate, brush, jump, logs etc. Frightening, dangerous or strange jumps are to be avoided.

## **Judging/Scoring**

1. When a horse makes two faults at one obstacle, only the major fault will be counted, except refusals, which will count in addition.
2. When an obstacle is composed of several elements in the same vertical plane, a fault at the top element is the only one penalized.
3. When an obstacle requires two or more fences (in and out) the faults committed at each obstacle are considered separately.
4. Judges shall penalize unsafe jumping and bad form over fences, whether touched or untouched.
5. In case of a refusal or run out at one element, entry must re-jump the previous as well as the following elements when course has been reset.
6. Circling once before beginning and after ending the course is permissible (see diagram).
7. Loss of impulsion will be scored as a refusal.
8. Touches are not to be considered but may be scored according to scale below for reference only in cases where elimination is difficult.
  - a. With any part of the horse's body behind the stifle – half Fault.
  - b. With any part of the horse's body in front of the stifle – one Fault.
  - c. Of standard of wing in jumping obstacle with any part of the horse, rider, or equipment – one Fault.
9. Knock-downs – Major Faults:

An obstacle is considered knocked down when its' height is lowered by horse or rider.

  - a. With any part of horse's body behind stifle – 4 Faults.
  - b. With any parts of the horse's body in front of stifle – 8 Faults.
  - c. Of standard or wing in jumping obstacle with any part of horse, rider or equipment – 8 Faults.
  - d. Of obstacle by touching a wing or post; it shall count as a knockdown of obstacle with above penalties.
  - e. Placing any foot in Liverpool, ditch, or water – 8 Faults.
  - f. Hind knockdowns, not the fault of bad jumping, shall not necessarily eliminate horse from an award but should be scored against in a comparative manner.
  - g. When a horse touches an obstacle, causing a rail of an adjoining panel or wing to fall, it shall not be construed as a knockdown.
10. **Disobedience (major faults)**

Circling once upon entering the ring and once upon leaving is permissible:

  - a. 1<sup>st</sup> refusal, run out, bolting on course, extra circle – 3 faults.
  - b. 2<sup>nd</sup> refusal, run out, bolting on course, extra circle – 6 faults.
  - c. 3<sup>rd</sup> refusal, run out, bolting on course, extra circle – elimination.
  - d. Jumping an obstacle before it is reset – elimination.
  - e. Failure to keep proper course – elimination.
  - f. Jumping an obstacle not included in course – elimination.

## **11. Falls**

Horse and or rider falling in competition are eliminated.

## **HUNTER OVER FENCES**

1. After completing the course, no horse will be requested to re-jump the course.
2. Upon completion of the entire class over fences, the finalists may be asked to jog their horses past the judge to show soundness.
4. The judge will penalize unsafe jumping and bad form over fences, whether touched or untouched.
5. Fences should simulate obstacles, which might be found in the hunting field such as natural post and rail, brush, stonewall, gates, chicken coops, Aiken or hedge. Spreads over 4 feet are prohibited. The use of unusual objects not likely to be found under ordinary hunting conditions should be avoided.

### **Class Routine**

The hunter should provide his rider with a safe, consistent ride at a working pace over a course of fences similar to those that might be encountered in the field. This requires that all horses must be serviceably sound and any horse showing evidence of lameness, broken wind or impairment of vision will be refused an award and will be excused from the ring by the steward, show veterinarian, or judge.

Each horse will individually negotiate a course consisting of at least 8 jumps over a minimum of 4 different obstacles. At least one change of direction is recommended. The course must meet the approval of the judge.

### **Judging/Scoring**

To be judged on performance, manners and soundness with emphasis on performance and manners. The scoring of performance will be based on the maintenance of an even hunting pace, manners, jumping style and way of moving over the course. Although faults are taken into consideration, final placing will not rely solely on this.

### **Disqualifications**

Same as for Hunt Seat Equitation Over Fences and as listed under Judging/Scoring.

## **HUNTER HACKS**

Saddles of hunt or balance type preferred. Regulation snaffles recommended or Pelhams with Cavesson nosebands and flat curb chain or straps. Kimberwicks and uxeter bits are allowed. A judge, at his/her own discretion, may penalize horses with non-conventional types of bits and nosebands.

Martingales are optional in classes over fences; they are prohibited in classes not to jump. Any change of equipment during a class may be penalized at the discretion of the judge. Dropped, flash or figure eight nosebands are not permitted in any class under the hunt seat division.

### **Class Routine**

Horses are to be shown at a walk, trot, canter, and a hand gallop both ways of the ring. The judge may ask for extended trot. All horses are required to jump two fences. It is

recommended that these fences be no more than three feet high. The horse should be similar to the Hunter Under Saddle in that he is obedient, alert, and responsive and moves freely with a ground-covering gait. His style of jumping should be smooth and consistent such as that he could be relied on to take his rider over fences in a safe, obedient manner at an even hunting pace.

1. All contestants will enter the ring in a counterclockwise direction until otherwise directed by the judge. All exhibitors will be asked to hand gallop in groups of not more than eight at a time.
2. After all horses have been worked as specific in number 1; the judge may then dismiss any horse not being further considered in the class.
3. The judge may continue to work the remaining horses.
4. After the gallop, the judge may ask the group to halt and stand on a free rein.
5. The judge may ask any rider to back his horse in a straight line.
6. After horses have been worked on the flat, the judge will ask all horses to jump two fences each, no more than three feet in height.

## **WESTERN DIVISION**

### **APPOINTMENTS**

#### **Required**

1. ASTM/SEI Helmet
2. Shirt or jacket with long sleeves. It may be short-sleeved shirt if the rider is also wearing a jacket. Other western attire in accordance with breed standards is allowed.
3. Western style pants or colored jeans must be clean, neat, and in good repair.
4. Appropriately heeled boots.

#### **Preferred**

Western boots

Gloves

#### **Optional**

1. If vest or jacket is worn, it should be a definite western design.
2. Spurs must have blunt rowels or no rowels and straps. Bluntness is at the discretion of the judge.
3. Chaps (not allowed in equitation).
4. Standard sliding, rundown, or skid boots on the rear fetlocks; and splint boots or bell boots on the front legs or soft wraps on either are optional appointments in Western Reining and Western Handiness.

### **Tack/Equipment**

1. The horse will be shown with a stock saddle, either slick or swelled with either a high or low cantle. However, the saddle must definitely be sized to fit both the rider and the horse. Silver equipment will not count over a good working outfit. Tapaderos and Australian stock saddles are prohibited.
2. The horse will be shown with a properly fitted western bridle and bit. The bridle should be as simple as possible with no Cavesson or drop nosebands being allowed. The bit will be a Standard Western bit of either solid or jointed mouthpiece. Standard Western bits may have either a leather or chain curb strap, either must be at least half an inch or wider and flat.

3. Any horse five and under may be shown in a bosal or snaffle. A bosal must be rounded in shape, constructed of braided leather or rawhide, and must have a flexible, non-metallic core attached to suitable headstall. Attached reins may be of hair, rope or leather. A standard snaffle bit is defined as a jointed, single, rounded, smooth mouthpiece; rings may be loose, egg butt, Dee, or center mounted. A bosal, hackamore or snaffle bit rider may ride with two hands.
4. Horses over five years, Bosals, hackamores, tie-downs, running martingales and draw reins are prohibited.
5. The position of the hand not being used for reining is optional; but it should be kept free of the horse and equipment and held in a relaxed manner.

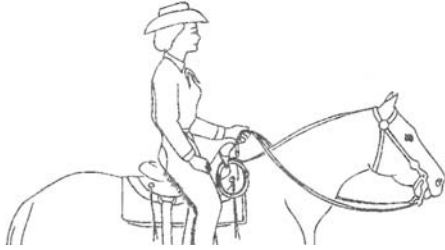

**Figure 1:** Illustrates hands when using split reins.



**Figure 2:** Illustrates hands when Romel is used. 16" of rein must be between hands; bite of reins optional as to coiled or straight.

**Figure 3:** Illustrates hands when using a snaffle bit and split reins. The reins must be crossed or bridged as shown here. When using a bosal the rider must have both hands on the reins. Riders hands should be carried near the pommel and not further than four (4) inches out on either side of the saddle horn, with very limited movement.



## **WESTERN HORSEMANSHIP (EQUITATION)**

### **Class Routine**

1. All contestants will enter the ring walking in a counter-clockwise direction until otherwise directed by the judge. They will be asked to walk, jog and lope both ways of the ring. Entrants will then be lined up for close inspection.
2. After all horses have been worked; the judge may then dismiss any riders not to be further considered in the class.
3. All riders may be required to execute any appropriate tests. Judges shall choose tests from the following list, or bring one of their own choosing, that is appropriate for the caliber of the class. The same test shall be given to all riders chosen for this additional performance.
  - a) Individual performance on the rail.
  - b) Figure eight at the jog.
  - c) Figure eight at lope, demonstrating simple or flying change of lead.
  - d) Lope and stop.
  - e) Ride without stirrups.
  - f) Dismount and mount.
  - g) Change leads down the center of the ring demonstrating either a simple change of lead or flying change of lead.
  - h) Serpentine at a lope demonstrating flying change of leads.
  - i) Demonstrate sliding stop at appropriate skill levels.
  - j) Execute 360 degree turns (spins).
  - k) Roll Backs.
  - l) Extend jog.

### **Judging/Scoring**

Emphasis in the class will be placed on the rider's ability to effectively control his/her horse and maintain his/her basic position while doing so. To be judged **90%** on rider's position, use of aids and cues and control of the horse, and **10%** on personal appointment and tack. The scoring of personal appointment and tack will be based on neatness of clothing rather than newness, expense, cleanliness, condition and adjustment of tack.

### **Disqualifications**

Refer to Saddle Seat Equitation.

## **WESTERN PLEASURE**

### **Class Routine**

A true pleasure horse is easy to handle, smooth gaited and does not show undesirable mannerisms. His overall performance should be smooth, consistent and obedient.

1. All horses enter the ring in a counter-clockwise direction. All horses will be asked to walk, jog and lope both ways of the ring. Horses will be asked to back, may be asked to extend jog.
2. After all the horses have been worked; the judge may then excuse those not to be considered further in the class.
3. The judge may ask for additional rail work from any of the remaining horses.
4. The method of holding the reins is the same as that for Western Horsemanship.

### **Judging/Scoring**

To be judged on manners, and performance and suitability of the horse as a pleasure mount. The smoothness, obedience and consistency of the performance will be considered rather than brilliance and animation.

### **Disqualifications**

Refer to Saddle Seat Equitation

## **WESTERN RIDING**

### **Class Routine**

This class is a competition in the performance of a sensible, well-mannered, free and easy going ranch horse which can get its rider around on the usual ranch chores, over trails, or give a quiet, comfortable and pleasant ride in open country and over obstacles.

1. All horses will follow the posted pattern. Any horse not following the exact pattern may be penalized or disqualified at the discretion of the judge.
2. The eight X's on the pattern represent markers (plastic or rubber cone-shaped markers recommended). These should be spaced a uniform distance apart. The preferred distance lengthwise between the markers is 40 feet, but if arena space is limited, they may be spaced 30 feet apart. Width-wise there should be a distance of 60 feet when the length is 40 feet and a distance of 50 feet when the length is 30 feet.
3. The rectangle represents an obstacle just high enough to break the horse's stride. This obstacle, if possible should be at least 12 inches high and not more than 18 inches high. A small log is recommended. A ground pole may be used if a more suitable obstacle is unavailable.
4. The long and sometimes twisting line indicates the direction to travel and the gaits at which the horse is to move. The dotted line (...) indicates the walk, the dash line (----) the jog, the solid line (\_\_\_) the lope.
5. If the horse runs into a marker, he will be penalized but not disqualified.
6. The method of holding the reins is the same as that for Stock Seat Equitation.
7. While the horse is in motion, the rider's hands will be clear of the horse and saddle.
8. Spurs or romal will not be used forward of the cinch.

### **Judging/Scoring**

The horse in this class will be judged on riding quality and smoothness of gaits, changes of lead, response to rider, manners, disposition, and intelligence. The horse should execute flying lead changes quietly and smoothly. Contestants will be penalized when the horse changes leads in the front but not behind and when horse shows signs of resistance to lead changes (tail-wringing, head tossing, etc.). When the horse is asked to go over the obstacle, he should do so smoothly and calmly; when asked to back, he should do so in a relaxed, obedient manner.

### **Disqualifications**

Same as for Saddle Seat Equitation plus as described in Class Routine.

# WESTERN RIDING PATTERNS

## Pattern I

WESTERN RIDING PATTERN I

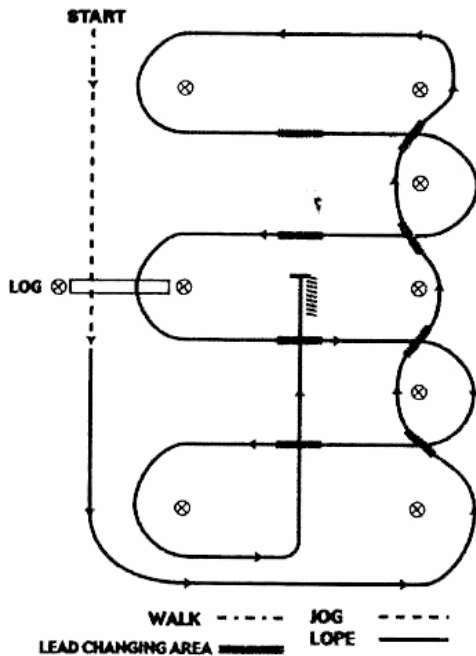

### Pattern I

1. Walk and jog over log.
2. Transition to left lead and lope around end.
3. First line change.
4. Second line change.
5. Third line change.
6. Fourth line change lope around the end of arena.
7. First crossing change.
8. Second crossing change.
9. Lope over log.
10. Third crossing change.
11. Fourth crossing change.
12. Lope up the center, stop and back.

## Pattern II

WESTERN RIDING PATTERN II

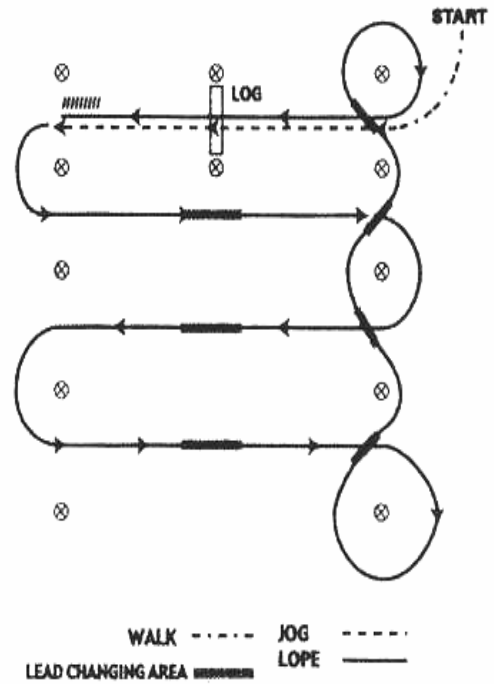

### Pattern II

1. Walk, transition to jog, jog over log.
2. Transition to left.
3. First crossing change.
4. Second crossing change.
5. Third crossing change.
6. Circle and first line change.
7. Second line change.
8. Third line change.
9. Fourth line change and circle.
10. Lope over log.
11. Lope, stop and back.

## Pattern III

WESTERN RIDING PATTERN III

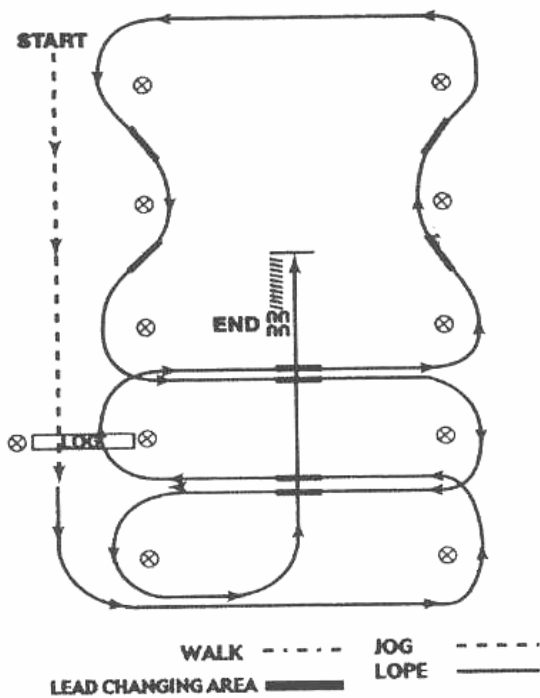

### Pattern III

1. Walk, transition to jog, jog over log.
2. Transition to left.
3. First crossing change.
4. Lope over log.
5. Second crossing change.
6. First line change.
7. Second line change.
8. Third line change.
9. Fourth line change.
10. Lope over log.
11. Third crossing change.
12. Fourth crossing change.
13. Lope up the center, stop and back.

## Pattern IV

WESTERN RIDING PATTERN IV

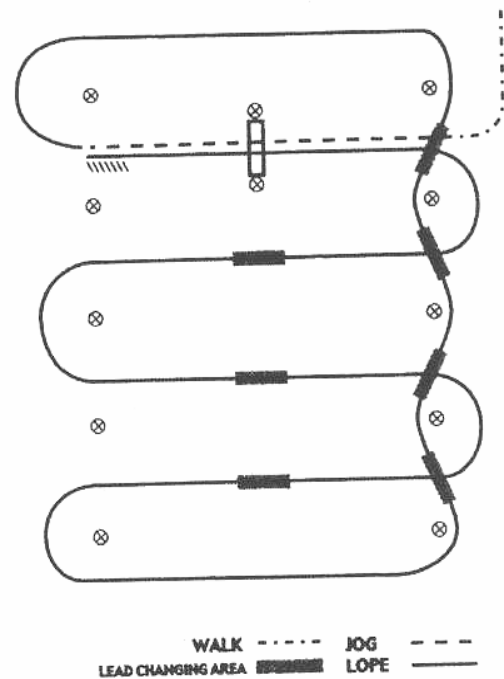

### Pattern IV

1. Walk, transition to jog, jog over log.
2. Transition to right.
3. First line change.
4. Second line change.
5. Third line change.
6. Fourth line change.
7. First crossing change.
8. Second crossing change.
9. Third crossing change.
10. Lope over log.
11. Lope, stop and back.

## WESTERN REINING

### Class Routine

The judge will indicate with markers on the arena fence or wall the length of the pattern. Markers within the area of the pattern will not be used. As each maneuver group is completed, the judge will make an assessment in accordance with the following scale:

+ 1 ½ .....	Excellent
+1 .....	Very good
+1/2 .....	Good
0.....	Correct
-1/2 .....	Poor
-1 .....	Very Poor
-1 ½.....	Extremely poor

These maneuver group scores are added to the starting score of 70 and from that gross score all penalties are subtracted to arrive at a final score.

GROSS SCORE (70 points. + Maneuver Group Score) Less PENALTIES = FINAL SCORE

### Maneuvers

1. **Stops**: Stops are the act of slowing the horse from a lope to a stop position by bringing the hind feet and hocks under the horse in a locked position and sliding on the rear shoes. The horse should enter the stop position by bending the back and bringing the rear legs and hocks further under the body while maintaining forward motion and ground contact with the front legs. Throughout the stop, the horse should continue in a straight line and the position of the hocks, rear feet, and back should not vary.
2. **Spins**: Spins are a series of turns, executed over a stationary (inside) hind leg. Propulsion for the spin is supplied by the outside hind leg and front legs, and contact should be made with the ground and a front leg. The location of the hindquarters should be fixed at the start of the spin and maintained throughout.
3. **Rollbacks**: Rollbacks are the 180° reversal of forward motion completed by running to a stop, rolling (turning) the shoulders back to the opposite direction over the hocks and departing in a lope, as one continuous motion. The rollback must be executed with not more than slight hesitation after the stop, and the horse should not step ahead or back prior to the rollback.
4. **Circles**: Emphasis on scoring shall be given to the contestant exhibiting smooth, controlled figure eights with easy lead changes. Circles are a controlled maneuver at the lope in the designated area of the arena. Right and left circles shall have a common centerline in the middle of the designated area. Circles shall be run and/or begun on the correct lead. The speed and size of the right circles shall be exactly the same as the speed and size of the left circles. The horse shall lope in an even, fluid manner with a minimum of rider contact and/or commands. Circles shall be run far enough from arena wall that it does not affect the circles.
5. **Back ups**: A back up is maneuvers requiring the horse to be moved in a reverse motion in a straight line a required distance (i.e. at least 10 feet).
6. **Hesitate**: Hesitation is only long enough to show the completion of one maneuver before the next one starts. There shall be the slightest hesitation to indicate each maneuver.

7. **Lead Changes**: Lead changes are the act of changing the leading legs of the front and rear pair of legs, at a lope, when changing the direction traveled. The lead change must be executed at the lope with no change of gait or speed and be performed in the exact geographical location in the arena specified in the pattern description. The change of front and rear legs must take place within the same stride to avoid penalty.
8. **Run Downs**: Run downs are the run through the middle of the arena, runs from the center of the arena to the end, and runs along the side and ends of the arena.
9. **Definition of Fall of Horse**: When the horse's shoulder and hip are on the ground and all four feet facing in one direction. Fall of horse in any event receives a score of -0-.

## **Penalties**

### **Half-Point Penalties**

1. Not changing leads in the same stride.
2. Over or under spin 1/8 turn.
3. Jogging first two strides.

### **1 Point Penalties**

1. Not changing leads each quarter circle.
2. Slipping a rein in the bridle.
3. Scotching or anticipating a stop.
4. Over or under spinning up to quarter turn.
5. Lead missed around end of arena first corner to top.
6. Out of leads for each quarter circle.
7. Not picking up the correct lead for the first quarter circle.

### **2 Point Penalties**

1. Lead missed around end of arena past 2<sup>nd</sup> corner.
2. Not ever changing leads in pattern where there is only half circle.
3. Failure to run by markers before stop is initiated.
4. Freezing up in turn or rollback.
5. Breaking gait.
6. Jogging beyond two strides.

### **4 Point Penalties**

1. Not ever changing leads in a complete circle.

### **5 Point Penalties**

1. Spurring or hitting front of cinch.
2. Blatant disobedience including kicking, biting, bucking, rearing, and striking.
3. Not achieving a stopping position.

### **--0--Score**

1. Failure to complete the pattern given (i.e., over or under spin more than quarter).
2. Using 2 hands on the reins in a bridle or two-rein class.
3. Fingers between the reins in a bridle class except in the two rein class.
4. Horse balking.
5. Failure to maintain 16 inches' of rein between hands using romal reins.

6. Use of free hand while holding a romal to alter the tension or length of reins from the bridle to the reining hand.
7. Leaving the working area before pattern is complete.
8. Fall of horse or rider.

### **Judging/Scoring**

The arena or plot will be 50 x 150 in size.

1. The pattern to be used will be posted by the judge at least 1 hour prior to the competition. It shall be a pattern from this rulebook.
2. Protective boots, leg wraps and bandages are permitted.
3. A suggested pattern is shown (see diagram in this section).
4. Judging and Scoring:
  - a. Scoring will be on the basis of 60 - 80 with 70 denoting an average performance. To be judged on the neatness, precision, dispatch, ease, calmness, and speed with which the pattern is performed. Off pattern will result in disqualification.
  - b. Faults against the horse (to be scored accordingly, but not to cause disqualification):
    - i. Opening mouth excessively when wearing a bit.
    - ii. Excessive jawing, opening mouth or head rising on stop.
    - iii. Breaking gaits.
    - iv. Lack of smooth, straight stop on haunches (bouncing or sideways stop).
    - v. Failure to change leads.
    - vi. Anticipating signals.
    - vii. Stumbling or falling.
    - viii. Backing sideways.
    - ix. Knocking over markers.
  - c. Faults against the rider (to be scored accordingly, but not to cause disqualification). The judge can assume infractions of these rules are due to lack of control on the part of the rider:
    - i. Changing hands on reins.
    - ii. Two hands on reins (only one hand permitted on the reins, one finger permitted between the reins).
    - iii. Holding on to any part of the saddle.
    - iv. Any unnecessary aid given by rider (such as excessive talking, spurring, whipping, jerking of reins, etc.).
  - d. Disqualifications:
    - i. Off course
    - ii. Fall of horse and rider.
    - iii. Horse being unruly or out of control.

### Pattern 1

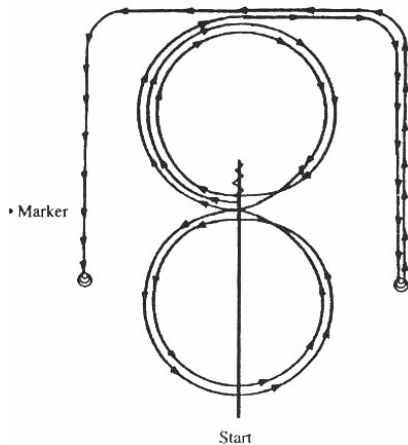

### Pattern 1

1. Start at end of arena. Run down middle past center marker to a sliding stop.
2. Back up 10-15 feet to center, quarter turn left.
3. Pick up right lead, big fast circle, and small slow circle.
4. Change leads to left, big fast circle, small slow circle.
5. Change leads to right, do not close this circle.
6. Run around end of arena and down the side (approximately 20 feet from fence) past center marker and come to a sliding stop.
7. Complete  $3\frac{1}{2}$  spins to right.
8. Continue back down side and end of arena to other side (approximately 20 feet from fence) go past center marker and come to a sliding stop.
9. Complete  $3\frac{1}{2}$  spins to the left.
10. Hesitate to complete pattern.

### Pattern 2

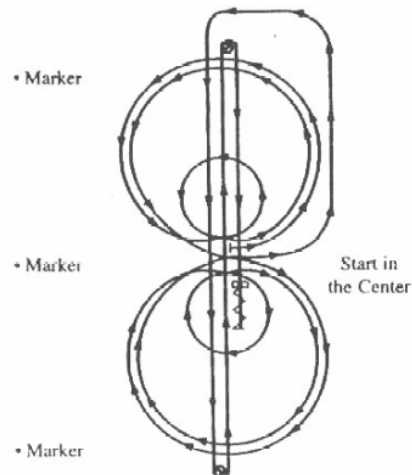

### Pattern 2

1. Trot to center of arena, stop. Pick up left lead; complete three circles to the left. The first one large and fast, the second small and slow, the third large and fast.
2. Leads at center of arena.
3. Complete three circles to the right. The first one large and fast, the second small and slow, the third large and fast.
4. Change leads at center of arena.
5. Do not stop, continue on to run-downs.
6. Run to far end past the marker to a sliding stop. Hesitate.
7. Complete  $2\frac{1}{2}$  spins to the left. Hesitate.
8. Run to far end past the marker to a sliding stop. Hesitate.
9. Complete  $2\frac{1}{2}$  spins to the right. Hesitate.
10. Run past center marker to a sliding stop. Hesitate.
11. Back 10-15 feet in a straight line. Hesitate.
12. Make 2 full spins each way, either way first. Hesitate between spins.
13. Hesitate to complete pattern.

### Pattern 3

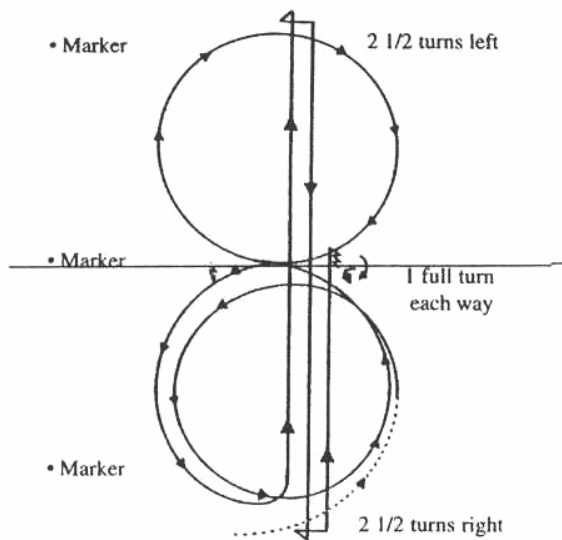

### PATTERN 3

1. Start at center of arena.
2. Begin on left lead, complete one circle, change to the right.
3. Complete one circle to the right, change leads to the left.
4. Do not stop; continue loping to end of arena without breaking gait.
5. Run to far end past the marker and come to a sliding stop.
6. Complete 2½ spins to left.
7. Run to far end past the marker, come to a sliding stop.
8. Complete 2½ spins to the right.
9. Run back to middle of the arena past the center marker and come to a sliding stop.
10. Back 10-15 feet in straight line.
11. Complete one full turn each way, either way first.
12. Hesitate to complete the pattern.

### Pattern 4

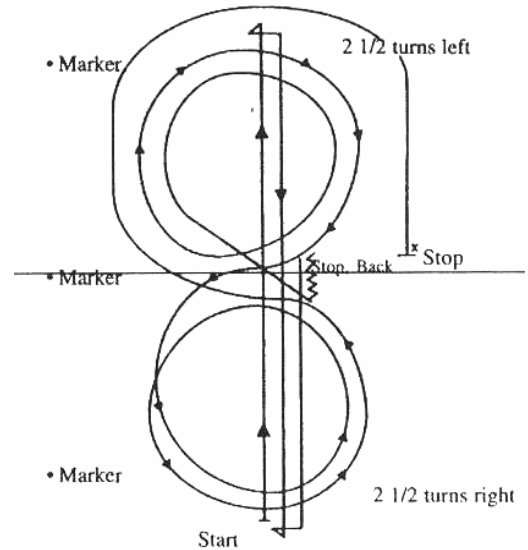

### PATTERN 4

1. Start at end of arena.
2. Run to far end of arena past the end marker and stop. Complete 2½ spins to the left.
3. Run to other end of arena past the end marker and stop. Complete 2½ spins to the right.
4. Run past the center marker and stop.
5. Back 10-15 feet in straight line.
6. Complete ¼ turn to the left, hesitate. Begin on right lead, circle to the right.
7. Complete one small, slow circle and one large, fast circle. Change leads to the left.
8. Complete one small, slow circle and one large, fast circle. Change leads to the right.
9. Run around end of arena to the other side, past center marker, at least 20 feet from fence and stop.
10. Hesitate to complete pattern.

## Pattern 5

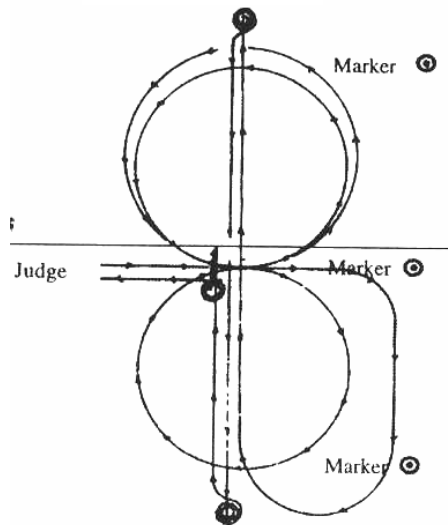

### PATTERN 5

1. Begin at the center of the arena, facing right wall or fence. Take a right lead and complete a circle to the right, away from the judge.
2. At the center of arena, change leads and do two circles to the left of approximately the same size.
3. At the center of arena, change leads.
4. Go to the end of the arena and without stopping or breaking gait, start the run near the approximate center marker of the arena. Run full length of arena.
5. Do a square sliding stop, hesitate.
6. Do 2½ spins right.
7. Run full length of arena past marker and do a square sliding stop, hesitate.
8. Do 2½ spins left.
9. Run past center marker of arena; do a square sliding stop.
10. Back to center of arena (minimum 10-15 feet).
11. Do a 360° spin right or left.
12. Do a 360° spin opposite direction taken in #11.
13. Hesitate to show completion of pattern.

## Pattern 6

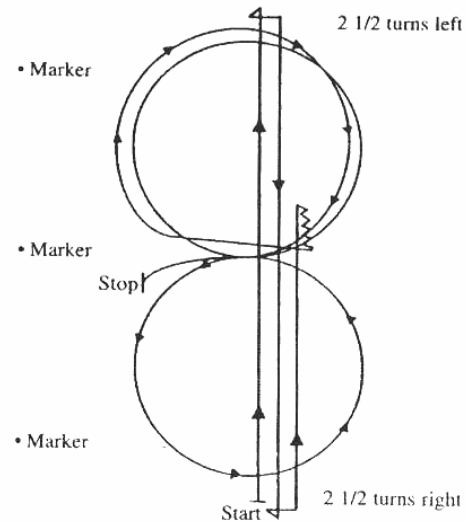

### PATTERN 6

1. Start at end of arena.
2. Run down the idle of the arena, past the end marker and come to a sliding stop.
3. Complete 2½ spins to the left.
4. Run to the other end of the arena past the end marker and come to a sliding stop.
5. Complete 2½ spins to right.
6. Run back to middle of the arena, past the center marker and stop.
7. Back 10-15 feet, hesitate.
8. Complete ¼ turn to the left.
9. Start to circle to the right, change leads in the middle to the left leads. Complete circle and change to the right leads. Close circle and stop.
10. Hesitate to complete pattern.

## Pattern 7

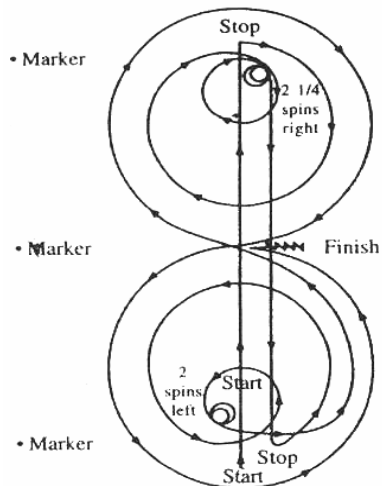

### PATTERN 7

1. Proceed to end of arena. Run down in the middle of the arena, past end marker and come to a sliding stop. Hesitate.
2. Complete  $\frac{1}{4}$  turn to the right, pick up right lead, and make one large, fast circle and one small, slow circle. Stop.
3. Complete  $2\frac{1}{4}$  spins to the right. Hesitate.
4. Run down to end of arena, past end marker and come to a sliding stop. Hesitate.
5. Complete  $\frac{1}{4}$  turn to the left, pick up left lead and make one large, fast circle and one small, slow circle. Stop.
6. Complete 2 spins to the left. Hesitate.
7. Pick up left lead to make one figure eight, change in center of arena to right lead. Proceed back to center of arena and change leads to the left. Close circle, stop.
8. Back 10-15 feet.
9. Hesitate to complete pattern.

## Pattern 8

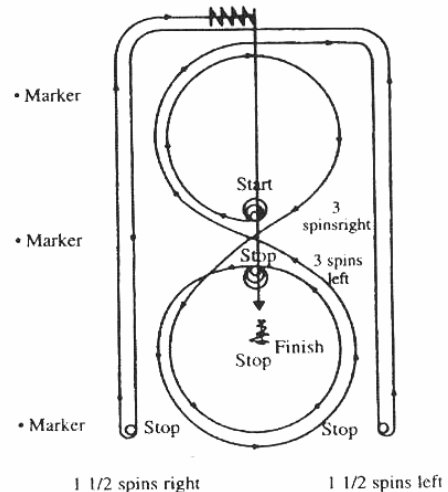

### PATTERN 8

1. Start in center of arena and complete 3 spins to the right. Hesitate.
2. Begin on right lead, complete one circle to the right, change leads to the left, close this circle and stop.
3. Complete 3 spins to the left. Hesitate.
4. Begin on left lead, circle to the left, change leads to the right.
5. Do not close this circle. Run straight down side of arena approximately 20 feet from the fence, past end marker and come to a sliding stop.
6. Complete  $1\frac{1}{2}$  spins to the left.
7. Continue back down side of arena approximately 20 feet from fence, around end of arena (horse should be on the left lead at this point). Run straight down other side of arena approximately 20 feet from fence, past end marker and come to a sliding stop.
8. Complete  $1\frac{1}{2}$  spins to the right.
9. Continue back down side of arena approximately 20 feet from fence, around the end of arena (horse is to be on the right lead at this point). Run straight down middle of arena, past middle marker and come to a sliding stop.
10. Back 10-15 feet.
11. Hesitate to complete pattern.

## **WESTERN HANDINESS**

### **Appointments/Tack/Equipment**

Same as Western Division with the addition of a costume and music.

### **Class Routine**

This class is a pattern class. It is the exhibitor's responsibility to be prepared to do what is expected of horse and rider. This class is neither a stunt class nor a race, but should be performed with reasonable speed. It is a completion in the performance and characteristic of a good, sensible, well-mannered, free and easy moving horse. Horses will be judged on riding qualities of gaits, response to rider, and manners and disposition. Maximum time limit for each exhibitor is 3 minutes.

### **Required Movements**

- a. Two flying lead changes, one in each direction.
- b. Two stops.
- c. Two large fast circles, one in each direction.
- d. Two small slow circles, one in each direction.
- e. Two rollbacks.
- f. Two 360° turns and one pivot.
- g. Settling horse for 5 seconds.
- h. Back 5 steps.

### **Other Judged Requirements**

- a. Suitability of music.
- b. Costuming.
- c. Horse's quality of gaits.
- d. Horse's response to rider in executing pattern.
- e. Manners and disposition of horse.

### **Judging/Scoring**

This class starts when the exhibitor enters the arena/ring and judging will cease after the last maneuver.

### **Disqualifications**

The following will result in disqualification:

- i. Abuse of animal in show arena/ring and/or evidence that an act of abuse has occurred prior to or during the exhibition of the horse in competition.
- ii. Use of illegal equipment, including illegal bits, wire on bits, Bosals, or curb chains.
- iii. Use of tack collars, tie downs, or nosebands.
- iv. Use of whips or bats.
- v. Use of any attachments which alters the movement of, or circulation to, the tail.

### Disqualifications continued

- vi. Failure to provide horse and equipment to the appropriate judge or official for inspection.
- vii. Disrespect or misconduct by the exhibitor.
- viii. Failure to complete the pattern in the specified order.

### Penalties

The following will result in a reduction of exhibitor's score.

- i. Balking or refusal of a command where the pattern is delayed.
- ii. Jogging in excess of half circle or half the length of the arena.

If technical difficulties occur with the music, which is beyond the rider's control, it will be at the discretion of the judge whether the rider may re-start.

### Handiness Pattern

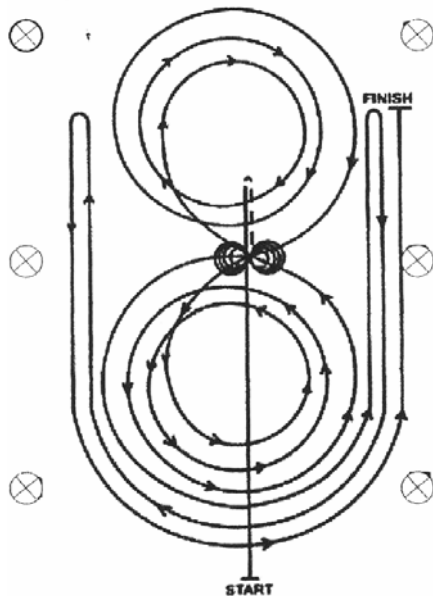

1. Run past the center marker and stop.  
Back up 5 steps. Hesitate for 5 seconds.
2. Complete 360° turn to the right.
3. Complete 360° turn to the left.
4. Pivot to left 90°
5. Beginning on the left lead, complete three circles to the left - the first circle small and slow; the next two circles large and fast. Change leads at the center of the arena.
6. Complete three circles to the right - the first circle small and slow; the next two circles large and fast. Change leads at the center of the arena.
7. Begin a large, fast circle to the left but do not close this circle. Run up the right side of the arena past the center marker and do a right rollback at least twenty feet (6 meters) from the wall or fence – no hesitation.
8. Continue back around the previous circle but do not close this circle. Run up the left side of the arena past the center marker and do a left rollback at least twenty feet (6 meters) from the wall or fence – no hesitation.
9. Continue back and around previous circle but do not close this circle. Run up right side of the arena past the center marker and stop at least twenty feet (6 meters) from the wall or fence. Stop and hesitate to demonstrate completion of the pattern.
10. Rider may drop bridle to the designated judge.

**Adopted from the AMERICAN QUARTER HORSE ASSOCIATION Reining Pattern #9**

## MISCELLANEOUS CLASSES

### TRAIL CLASS

#### Trail classes may be handled in three ways:

1. Trail obstacles only.
2. Trail obstacles and performance on the rail.
3. Outside course with suitable obstacles.

#### Judging/Scoring

1. Time in excess of 30 seconds, or 3 attempts in approaching an obstacle will eliminate the score for the obstacle and the rider will proceed to the next obstacle.
2. Failure to maintain correct gait where specified will be penalized.
3. This class will be judged on the performance of the horse over obstacles, with emphasis on manners, response to the rider, and attitude.
4. A course diagram shall be posted at least one hour before the class is held. This diagram will indicate obstacles order, paths to be ridden, and gait (walk, trot/jog, canter/lope) to be executed through course.

#### Overall Disqualifications

1. Rider will be disqualified for taking obstacles out of order.
2. Refer to respective equitation section for other disqualifications.
3. It will be a DQ if the rider touches their horse in any way (such as patting to reward) at or between obstacles. They may do so after acknowledgement of the judge at the completion of the class.

#### Appointments

##### Rider/Handler

Attire may be either English or Western, but not a mixture. Attire must be neat, clean, and comply with the rules in the appropriate divisions.

##### Tack

All tack shall be clean, and in serviceable condition. Saddles should fit the horse and rider. Tack used shall comply with the rules in the appropriate divisions.

##### Class Routine

1. Credit will be given to horses negotiating the obstacles with style and consistency while negotiating obstacles, providing carefulness is not sacrificed, and to horses showing the capability of picking their own way through the course when obstacles warrant it, and willingly responding to rider's cues on more difficult obstacles.
2. Horses with artificial appearance over obstacles shall be penalized.
3. Horses may not be required to work on the rail. However, the course must be designed to require each horse to show the gaits appropriate to their division (walk, trot/jog, canter/lope) somewhere between the obstacles as part of its work and will be scored as a maneuver.
4. A minimum of 6 obstacles will be used. Gaits between obstacles shall be at the discretion of the judge or show management. The course shall be returned to its original design after each horse has worked. Management, when setting a course, should keep in mind that the idea is not to trap a horse or eliminate it by making an obstacle too difficult.

5. The judge has the right and duty to alter the course in any manner, to remove any obstacles he deems unsafe before the start of the class. All courses and obstacles are to be constructed with safety in mind so as to eliminate any accidents.

### **Obstacles**

Each show committee must plan its course in advance of the show date. The following list is a guideline for the most common obstacles. **Safety is the major importance.**

1. Bridge – Should be sturdy enough to hold the weight of a large horse (1200 lbs or more). The floor should be a solid platform and not more than 12 inches high. The length should be about 8 feet, and width about 4 feet.
2. Mailbox – Exhibitor should remove object, show it to the judge and replace object.
3. Logs – Approximately 4-6 inches in diameter should be placed on the ground for the horses to walk over. They should be approximate.
  - Walkovers: 20-24 inches apart.
  - Jog or trot overs: 3 feet to 3 feet 6” inches apart.
  - Lope or canter over: 6 to 7 feet apart.
4. Objects for the riders to carry (such as a raincoat): The riders should be able to pick up the object from a jumping standard, fence post, barrel, etc. and move it to another area of the ring. This should not be used in walk-trot.
5. Backing- (for example, made by lying poles parallel to each other on the ground or elevated by some object. Poles should be at least 6 inches in diameter).
5. Cones – Placed so that the horse has to perform a serpentine pattern around them.
6. Jump – Should not be less than 12 inches and not more than 18 inches high and should fall on contact. Standard jumps may be used. The course must specify to ride or lead the horse over the jump and at what gait this shall be done. Should not be used in walk-trot.
7. Gate.
8. Side pass.
9. In the interest of safety, do not ask the rider to drag anything.

Each entry will be allowed a maximum time of 30 seconds or three attempts to pass each obstacle.

### **Judging/Scoring**

Class will be judged on performance, manners, and suitability - in that order, and neatness and cleanliness of horse, tack and rider. The following will result in a no score for the particular obstacle but does not mean disqualification from the class.

1. Taking an obstacle in the wrong direction.
2. Negotiating an obstacle from the wrong side.
3. Not following the correct line of travel.
4. Three refusals at each obstacle.
5. If the show committee wishes to modify the time allowed for a particular obstacle this must be posted in the course diagram.

## **COMMAND CLASS**

### **Class Routine**

Open to all 4-H'ers and their horses and ponies of any breed or combination of breeds. Divisions may be, but are not limited to, junior and senior riders.

This is an elimination contest where any rider not executing the judge's exact commands promptly and correctly will be eliminated. Individuals may be stationed at various points in the ring to aid in observing and eliminating contestants. The judge may ask contestants to walk, jog or trot, canter or lope, reverse, halt, back, to go from any gait to any other gait and to canter or lope in a counter lead. It is recommended that all judges establish in advance what is to be considered a fault. This class may be divided into sections for English and Western riders, or other divisions if the show management wishes.

### **Special procedure**

Each command will be given twice. By the time the second command is given, the horse must be performing that command. When at the halt, movement forward, backward or to the side will result in elimination. Judges are encouraged to be the announcer for this class.

### **Judging/Scoring**

Awarding of ribbons is to be based on the order of elimination of final contestants. This is an elimination class. Horses are excused as they fail to follow commands immediately.

## **VERSATILITY CLASS**

To be judged as a pleasure class with clear difference between English and Western gaits.

### **Appointments**

Appropriate for each seat.

### **Class Routine**

To be shown English and Western by the same rider (the class list should specify which seat to be shown first), changing tack and appointment in the ring. Horses should be asked to back in both seats.

### **Judging/Scoring**

See respective Pleasure Classes.

### **Disqualifications**

See respective Pleasure Classes.

## **4-H HORSE PROJECT CLASS**

To be judged 60% on riding ability, suitability of mount to rider and control of mount; and 40% on general knowledge, to be determined by questions from the judge. Danish ribbons to be awarded.

### **Class Routine**

To be shown at a walk, trot/jog, canter/lope (depending on division) both ways of the ring and back. Horses may be asked to extend the trot/jog. Each exhibitor will be asked the same questions by the judge.

### **Disqualification**

See respective Equitation Classes.

### **4-H CLUB CLASS**

To be judged on ability to work together, originality, and style of performance.

### **Special appointments**

Costumes and props as needed.

### **Class Routine**

Two or more members of a club will be given 3 minutes in which to complete a program of their choice. Music is optional (show management should designate whether exhibitors should provide their own players, or whether tapes or CD's can only be played, etc.). Time starts as soon as: a) the music begins or b) someone enters the ring. At the end of 3 minutes, time will be called. No cantering/loping permitted. Questions may be asked.

### **Judging/Scoring**

Originality, creativity and workmanship

### **MINIATURE HORSE CLASSES**

Please refer to USEF rules for all miniature classes

### **DRIVING DIVISION**

Please refer to USEF rules for all driving classes

### **REINSMANSHIP CLASS**

Please refer to USEF rules

### **PLEASURE DRIVING CLASS**

Please refer to USEF rules

### **DRESSAGE DIVISION**

There are two dressage classes that may be readily incorporated into a standard horse show: Dressage Equitation and Suitable to Become a Dressage Horse. These classes do not require a dressage arena or any special equipment. Although a dressage judge is not mandatory, a judge knowledgeable in dressage must be used.

Because dressage tests require specifically measured and marked arenas with attention to footing, experienced personnel, and explicit timing and tests, it is not recommended to try to incorporate them into a standard horse show. If you are interested in organizing a Dressage Show, please consult the USEF rulebook and contact the United States Dressage Federation (ESDF).

### **Dressage Equitation and Suitable to Become a Dressage Horse**

#### **Appointments**

##### 1. Rider

- a. Informal attire: Traditional hunt seat attire; a short riding coat of any conservative color, ratcatcher or dress shirt with tie or choker, breeches or jodhpurs of any conservative color except white, boots or jodhpur boots, ASTM/SEI helmet. Gloves are optional.

- b. Formal Attire: solid (no pinstripe) black, navy blue or dark charcoal gray jacket, white riding shirt, white stock tie with plain pin fastened horizontally through the knot, white, canary, tan or buff breeches, black field or dress boots, white, black or brown gloves and ASTM/SEI helmet.
  - c. If jackets are excused, competitors must wear a solid white long or short-sleeved shirt without choker, tie or stock tie (no sleeveless or polo shirts).
  - d. Optional: One whip no longer than 4 feet including lash may be carried. Spurs are optional, but must be blunt, no rowels.
2. Tack: all tack should be clean, in serviceable condition and should fit horse and rider.
- a. Minimum Requirements: Dressage or hunt seat type saddle, a plain snaffle bridle and a regular Cavesson, a dropped noseband, a flash noseband, crescent noseband, or a crossed noseband. Except for the crescent noseband and except for buckles, the noseband must be made entirely of leather or leather-like material.
  - b. Bits: Only plain snaffle bits may be used. Bits may be of metal, leather, rubber or synthetic, or of metal covered with leather, rubber or synthetic, and must be smooth (no twists or corrugations) and solid. The mouthpiece of any bits must be made entirely of the same metal. Any rein must be attached only to the bit. Bits may be checked before entering the arena.
  - c. Not Allowed: Martingales, bits, guards, any kind of gadgets (bearing, side, running, balancing reins), any kind of boots or bandages, blinkers, ear plugs, nose covers. Seat covers, hoods are strictly forbidden (elimination).

### **Class Routine for Dressage Equitation**

1. To be shown at working walk, trot and canter both ways of the ring. The rider's position, seat and specifically the correct use and effect of the aids required by the Training and First Level Dressage tests are to be judged.
2. Movements shall be performed by the exhibitors simultaneously; however, the judge may ask for independent execution of certain tests.
3. Tests are as follows:
  - a. Transitions from one gait to the next, both up and down.
  - b. Transitions from walk to halt and vice versa.
  - c. Transitions from trot to halt and vice versa with or without stirrups.
  - d. Judge shall not require exhibitors to exchange horses.
4. Whips and blunt spurs are allowed. Horses shall be shown in plain snaffle.
5. The size of the class shall not be more than 15 riders.

### **Class routine for Suitable to Become a Dressage Horse**

1. To be shown at a walk, trot and canter both ways of the ring.
2. To be judged on the horse's potential to become a Dressage mount. These qualities are revealed by:
  - a. Freedom and regularity of the paces.
  - b. Harmony, lightness and ease of the movements.
  - c. Lightness of the forehand and the engagement of the hindquarters, originating in a lively impulsion.
  - d. Acceptance of the bridle with submissiveness throughout without any tenseness or resistance.

## **GYMKHANA DIVISION**

You may need to check your state liability rules regarding ring size before adding any Gymkhana classes. **Safety is of major importance.**

### **Appointments**

As appropriate for safety as deemed by the show committee.

### **Tack/Equipment**

May be either English or Western, but not a mixture.

### **Optional**

Bat or crop not exceeding 24"; crops must have flat "popper". Slip guards or kneepads, body protection vest, and blunt spurs (not to be used forward of the cinch). Non-standard equipment may be disqualified at the discretion of the judge.

### **Judging/Scoring**

Scoring is determined by time.

### **Disqualifications**

Any rider may be disqualified for any of the following reasons:

1. Failure to enter or leave the arena under control and without assistance.
2. Failure to begin the course within one minute of entering the ring.
3. Off course. This includes negotiation of obstacles in other than the specified order or in the wrong direction.
4. Touching an obstacle with the rider's hand, whether or not the obstacle is knocked down as a result of touching it.
5. An unsound horse as determined by the judge/steward/show committee.
6. Fall of the horse or rider.
7. Failure of exhibitor to wear correct number in a visible manner.
8. Abusive handling as determined by the judge. Abuse may include, but not limited to the following: excessive spurring, use of spurs in front of the girth, excessive use of bat or crop, hitting with the bridle reins, hitting the horse in any way in front of the girth, hitting with flag, etc.
9. Use of tack or equipment, which is prohibited; breakage of equipment, which prevents completion of class.
10. Lack of sufficient control of the horse by its rider. A rider that obviously has no control of their horse while doing the pattern and produces an unsafe ride.
11. Loss of helmet from exhibitor's person at any time while exhibitor is in the ring.

### **Penalties**

Obstacle knockdown, i.e. poles, barrels, etc., - 5 second penalty.

### **Class Routine**

The gate must remain closed and the horse comes to a halt inside the ring before the gate is opened again. All further stipulations by the show committee.

## Personnel

1. Two timers, if automatic timers are not used.
2. Designated or appointed supervisor to oversee individual class routines.

## Equipment

1. Cones to designate start and finish line for timed events.
2. Automatic timers or a minimum of 2 stop watches.
3. Tape measure.
4. Other equipment as specified in class routines.

A clearly marked visible starting line such as stakes, pylons, lime or cones must be provided. An electric timer or two stopwatches should be used. The time recorded by either method will be the official time. Time penalties will be added to official time to determine placing. Lowest time (including any penalties) wins. Timer failure will entitle a rider to a re-run and the time obtained will be used plus any penalties occurring in the re-run. Circling once before leaving the ring is permissible.

Two hands are permitted on the reins. A rider may hold onto the saddle at any time during the run. Knocking over obstacles is a five second penalty per obstacle knocked over. A rider may bump an obstacle without penalty if it does not fall over. However, touching an obstacle with your hand to hold it up or trying to reset it is a disqualification. An obstacle is considered knocked over if it rolls on its side or flips end-over-end even if it lands in the upright position.

The show committee/management shall designate the order in which the entries shall compete. Cruelty to or the abuse of an animal, including excessive use of a whip or other implement, by any person at a 4-H event will result in immediate dismissal from the grounds. All class fees will be forfeited.

## Cloverleaf Barrel Race

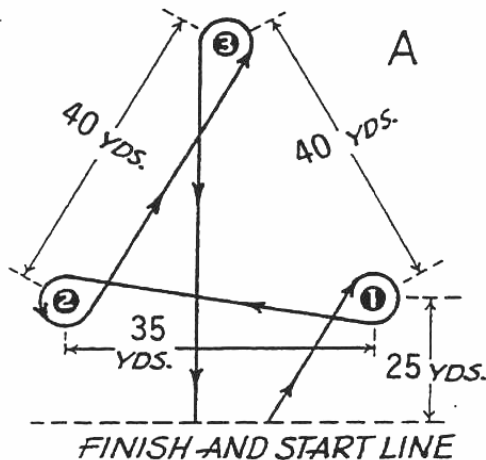

The contestant is allowed a running start and a choice of two methods of running the course. In the first method, at the signal from the starter, the entry will circle barrel number 1 clockwise, circle barrel number 2 counter-clockwise, circle barrel number 3 counterclockwise and then cross the finish line.

## Starting Line \_\_\_\_\_

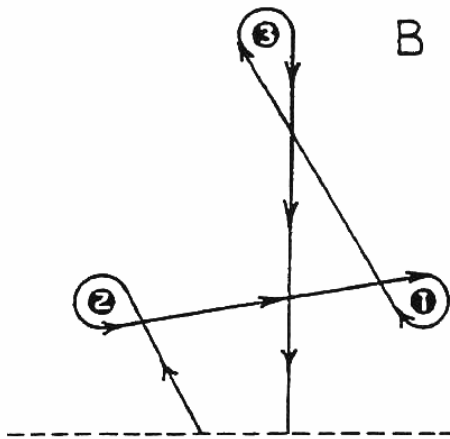

The course must be measured exactly. Barrels number 1 and 2 should be 25 yards from the timing line with a distance of 35 yards separating them. Barrel number 3 should be 40 yards from barrels 1 and 2. If the course is too long for the available space, the pattern should be reduced to 5 yards at a time until the pattern fits the arena. Adequate space should be allowed between the barrels and any obstacle. The distance from barrel number 3 to the finish line need not be reduced 5 yards at a time if there is sufficient room for the horse to stop. Barrels should be set at least 15-20 feet from the arena walls or fences so the horses must turn around barrels, not at the fence. You may need to check your state liability rules regarding ring size before adding any Gymkhana classes.

### **Flag Race**

Timed Event. A pail of sand with a flag in it will be placed at far end of ring. Contestant is given another flag. Contestant rides around pail, places flag in pail and picks up other flag and races back to finish line. Flag must be in pail when contestant crosses finish line or contestant will be disqualified. Hitting horse with the flag will mean disqualification. Must cross finish line with the second flag. Flags should be two different colors. *Variations of this race are available in different states.*

### **Keyhole Race**

The starting line will be 50-100 feet (according to arena size) from the entrance to the keyhole. The entrance will be 4 feet wide and 10 feet long, connected to a circle 20 feet in diameter, forming a keyhole.

The contestants will cross the starting line, proceed through the entrance, turn right or left in the circle making a complete 180 degree turn.

The contestant will then return through the entrance and cross the finish line.

In addition to the disqualifications listed under general rules for game classes, a contestant may also be disqualified if the horse steps on or outside of the chalk line marking the entrance and circle of the course.

# Keyhole Race

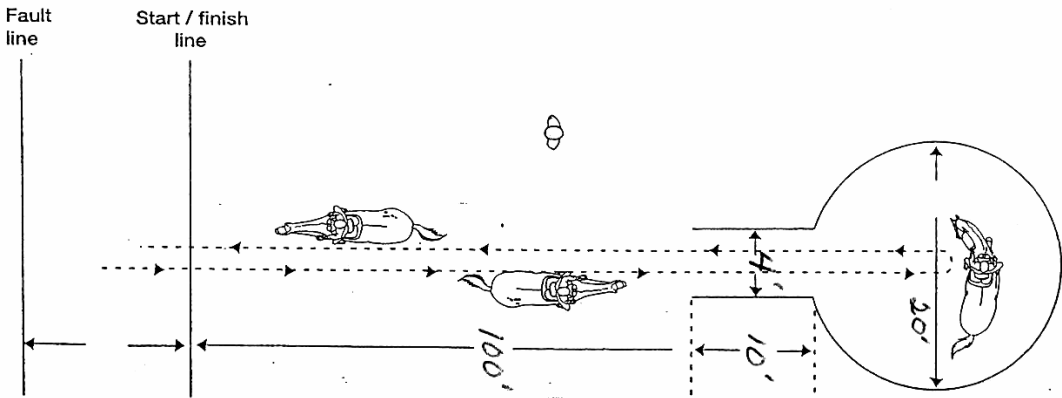

## Pole Bending

Poles (stakes) shall be approximately 1 ½" in diameter of a safe material that will not splinter. Each shall be from 6' – 7' high with a safe stable stand not more than 14 inches in diameter. Distances between poles and starting line to first pole may be reduced to 18' for pony competitors in a pony pole bending class.

### **PATTERN A**

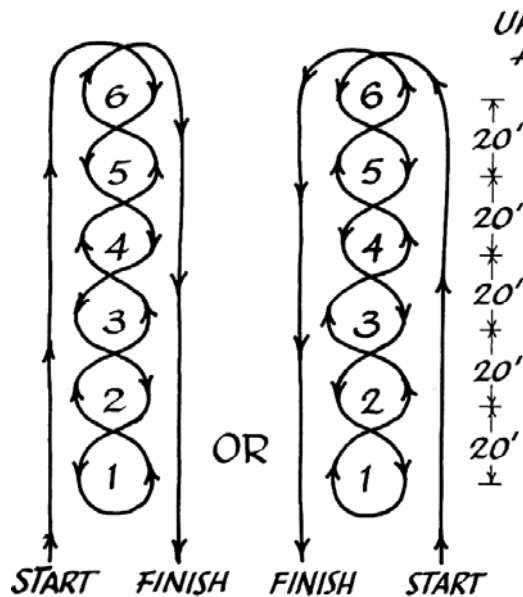

### **PATTERN B (Stake Race)**

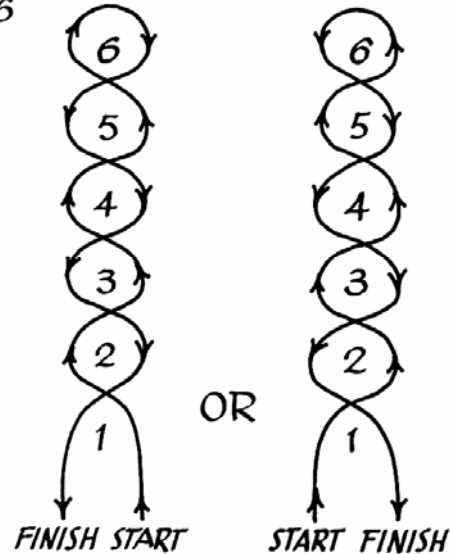

## Sit-A-Buck

### Class Routine

Each exhibitor must ride bareback without a training saddle, blanket, etc. Upon entering the ring, the judge places a piece of paper (approximately 3" x 5") under the rider's leg between the knee and buttocks. The horses are then worked at a walk, trot, and canter both directions of the ring. Any rider not performing the gaits asked by the judge in a reasonable amount of time is eliminated.

As exhibitors lose their paper, they are eliminated. The last to lose the paper is first; next to last, second, etc.

## EGG AND SPOON RACE

### Class Set Up

The exhibitors are each given 1 egg and 1 spoon (preferably hard boiled or wooden eggs will be used). **Regular silverware teaspoons should be used.** Plastic spoons and regular silverware shall not be mixed. After everyone has received an egg and spoon the riders must proceed at a walk around the ring. It is permissible to hold the egg in place with the thumb until everyone has entered the ring and the judge gives the word for the class to begin. The exhibitors must then hold the spoon by the handle at least 1 inch from the bowl and not touch the egg with the thumb or fingers. Touching of the egg with any part of the body after the class begins shall result in disqualification.

### **Class Routine**

The exhibitors will be asked to walk, trot/jog and canter/lope their mounts. If any exhibitors have their eggs after working both directions in the ring, the judge may ask for more intricate maneuvers such as stopping, riding with the feet out of the stirrups, backing up, or reverse at the trot/jog. Leads not to count unless specified to count by the judge. Any exhibitor not riding at the gait requested by the judge will be eliminated. As exhibitors lost their eggs, they will be eliminated. The last to drop the egg is the first; next to last, second, etc.

### **WATER RACE**

#### **Class Set Up**

Each exhibitor is given a paper cup filled with water. It is a good idea to use cups with some sort of design on them so the water can be measured easily.

#### **Class Routine**

The class is worked at a walk, trot, and canter for a set amount of time. Usually 3 to 5 minutes will be sufficient. Any exhibitor not riding at the gait requested by the judge will be eliminated. The riders with the most amount of water left in their cups at the end of the ride will be the winners. A variation of this class has the riders hold the cup on their open palm as they ride.

### **RIBBON RIDE**

#### **Class Set Up and Routine**

Entries are made in pairs; a pair consists of 2 horses and 2 riders. The riders hold between them a piece of paper (approximately 3" x 10") and ride as directed. Letting go of the paper by either rider or tearing (completely in two) of the paper eliminates the pair. Not riding at the gait requested by the judge eliminates the pair. The last pair to let go or tear their paper is first.

#### **Izzy Dizzy (see diagram this section)**

Class set up: Four cones to designate dismount area, horse handler, spotter and a bat.

#### **Class Routine**

Rider and horse ride to dismount area, dismount, lead horse to horse handler, run to bat, spin around bat a designated number of times (suggested 5 times) with head firmly touching bat (base of bat must stay on ground). Removal of head from bat requires participant to resume with spin #1). Upon completion of spins, participant then must run and cross finish line on foot.

# IZZY DIZZY

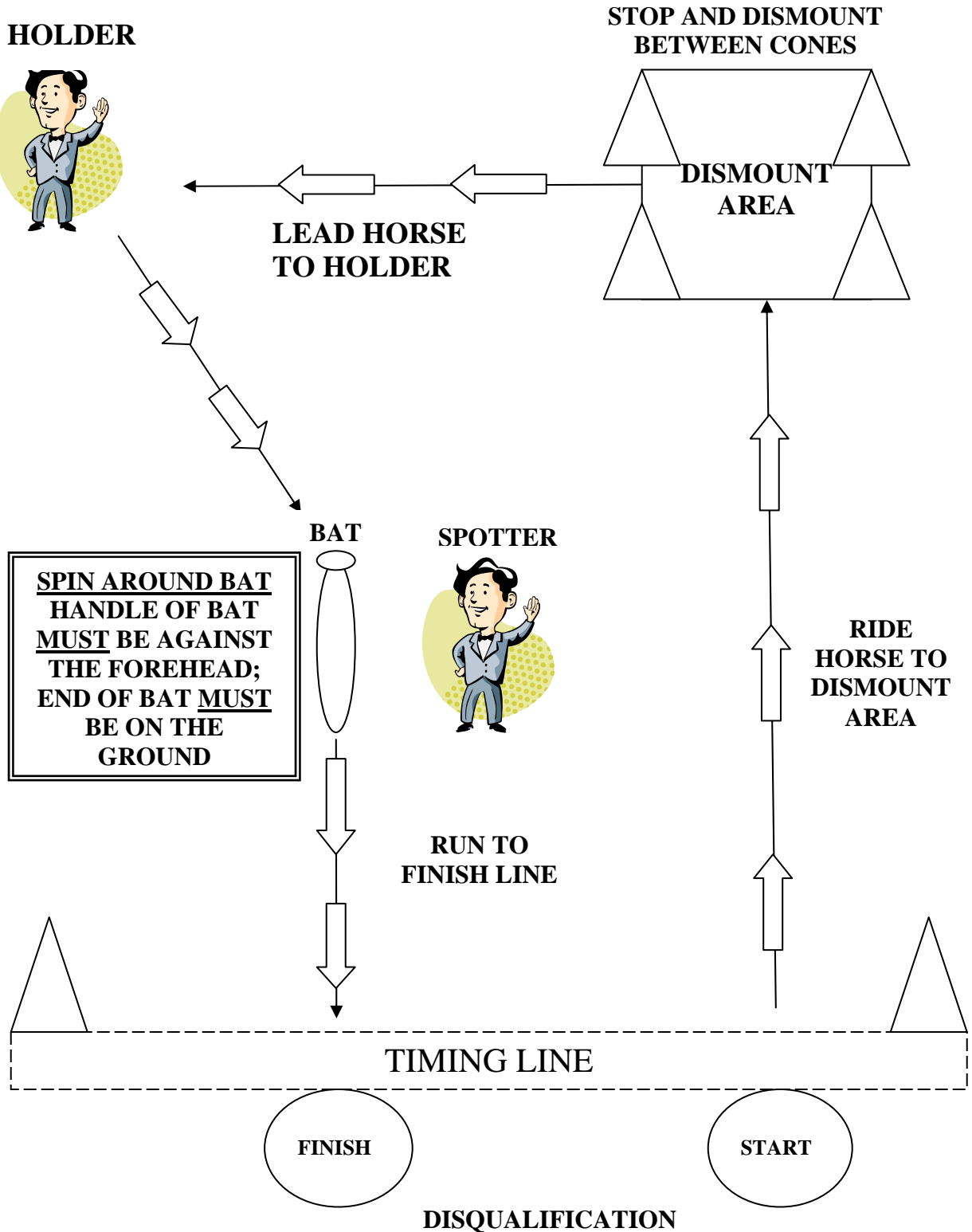

**Stopping And/Or Dismounting Anywhere Other Than Between The Dismount Area Cones. If The Competitor Over-Runs The Dismount Area, He/She Must Return To The Dismount Area, Stop And Dismount.**