



# WATER SUPPLY SITE DEVELOPMENTS

## TASK

Help the local Fire Department gather needed information to design, install and maintain storage and pump sites for fire suppression.

## DESCRIPTION

A detailed on-site evaluation is needed before completing a final design for construction. Information from the inventory would include: location, accessibility, available volume, type of development needed, cost estimate, site limitations and potential problems, and permit requirements. Detailed designs should be prepared by qualified designers for each site prior to construction.

## POTENTIAL BENEFITS

- ❑ Community benefits include: more strategically located water sources for firefighting, fuel savings for not hauling water from remote sites, and less vehicles on the road during emergency situations.
- ❑ Individual benefits include: security knowing adequate water supply is near by, possible wildlife habitat and recreational uses available in a pond, and possible insurance reduction benefits.
- ❑ A reliable uninterrupted flow of water is better for firefighting than tanker shuttle system with periods of water shortage.
- ❑ A list of potential water supply sites which can be used in planning for future development within the town.

## GUIDELINES

- ❑ Shown below is a typical dry hydrant installation and the primary factors affecting maximum flow available:

### Maximum Flow [A] is dependent on:

1. Elevation above sea level [B]
2. Static Lift [C]
  - a. Intake elevation of Pumper [D]  
(Should be higher than hydrant outlet)
  - b. Avoid static lifts exceeding 17 feet
3. Losses in Dry Hydrant
  - a. Pipe and Fittings [E]
    - 1) Diameter of pipe (6" minimum)
    - 2) Length of pipe and fittings  
(minimize length and number)
    - 3) Interior roughness
    - 4) Type of fittings
  - b. Strainer Type [F]
    - 1) Large metal strainer preferred over perforated pipe
  - c. Velocity Head [H]
    - 1) Diameter of pipe
  - d. Loss in sudden reduction and bends [G]
    - 1) Ratio of "Diameter larger" and "Diameter smaller" pipe

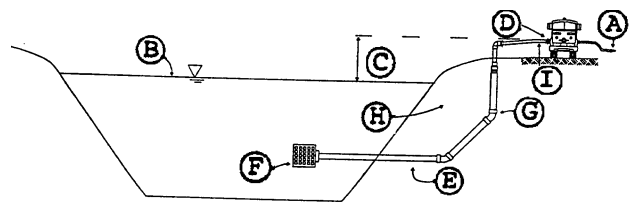

4. Loss in suction hose [I]
  - a. Length
  - b. Diameter
5. Installation depth [J] must be below the frost-free depth for the area. Recommend 5.0 foot elevation difference between water level and ground surface at the riser.
6. Detailed investigation of adequate pump out locations in streams is needed to determine bedload movement and natural scour holes for use as sumps for the installation of the dry hydrant.

□ The following information applies to the installation of a cistern:

1. Minimum Storage volume to be determined by local regulations or from National Fire Protection Association (NFPA) 1231 publication.

$$\text{Vol} = \frac{\text{TSV} (\text{ft}^3) \times \text{CC}^\#}{\text{OHC}^\#}$$

Where:

TSV = Total Structure Volume  
 CC# = Construction Class No.  
 OHC# = Occupancy Hazard Class No.

2. Lower suction pipe installed with anti-vortex plate, anchored and raised minimum of 6 inches off bottom.
3. Provide connection for filling the tank from above ground and consider method of directing roof stormwater into tank for circulating and maintaining levels.

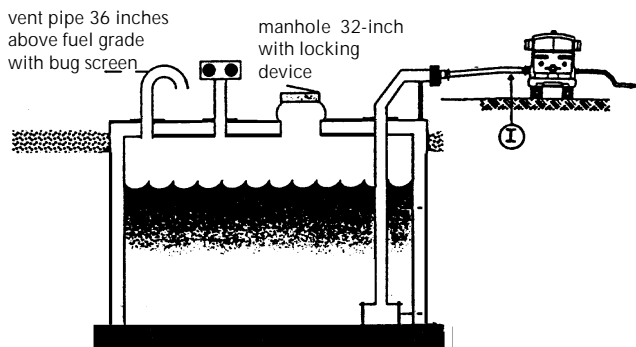

4. Consider soil conditions and possible high groundwater tables before installing a cistern.
5. Design and locate cistern so fire trucks don't drive over the tank to pump out water, and total lift doesn't exceed 17 feet.
6. Install cistern deep enough to prevent water from freezing.
7. Insure tank can withstand soil pressures when tank is empty.

□ Various materials can be used for the installation of pipes and hydrants.

1. Steel pipe for complete system is recommended for installations in streams or existing ponds which can't be lowered to see material in bottom of trench. Use 7.0 foot steel riser for this type of installation.
2. Six or eight inch PVC Schedule 40 pipe with 3.5 foot steel riser is recommended in the northern climates.
3. Fabricated metal strainer or trash guard is recommended on the inlet of the intake pipe rather than a perforated pipe.
4. PVC pipe must be placed on one foot of sand and covered with another foot of sand to protect it from rocks in the back-fill or original material.
5. Install guard posts on each side of riser (approximately 2 feet away) to protect from snow plows, vehicles, etc.
6. The use of two 45 degree elbows instead of a 90 degree elbow when connecting the riser to the suction line can reduce the head loss somewhat and facilitates getting the riser installed vertical.

---

□ Maintenance of hydrants and cisterns should include the following actions:

1. Hydrants should be backflushed and tested twice per year.
2. Inspect hydrants for any damage or leaks.
3. Inspect and insure adequacy of guard posts and access roads to the hydrant or water source annually.
4. Keep records of all inspections and tests noting maximum withdrawal rates.

## REFERENCES

- Planning for Water Supply and Distribution in the Wildland/Urban Interface. Publication # NSES 2295  
Available from: National Interagency Fire Center, 3833 South Development Ave., Boise, Idaho, 83705 (208) 387-5542
- Rural Firefighting Operations, by Larry Davis, International Society of Fire Service Instructors. Available from DBA Resource Center, 30 Main St., Ashland, Mass., 01721 (508) 881-5800

## WHERE TO GET MORE INFORMATION AND ASSISTANCE

- County Conservation District and Natural Resources Conservation Service (*See Directory*)
- New Hampshire Department of Resources and Economic Development  
Division of Forests and Lands  
Forest Protection Bureau  
P.O. Box 1856, Concord, NH 03302-1856, (603) 271-2217.
- University of New Hampshire  
Cooperative Extension  
Forestry and Wildlife Program  
121 Taylor Hall, 59 College Road,  
Durham, NH 03824, (603) 862-2619, or contact the UNH Cooperative Extension office in your county. (*See Directory*)
- The National Fire Protection Association  
1 Batterymarch Park, P.O. Box 9101,  
Quincy, Mass., 02269-9101 (617) 770-3000



