



4-H HARNESS GOAT PROJECT

PHOTO OF YOUR
4-H PROJECT
GOAT

Name: _____

Age: _____ **Birthdate:** _____

Address: _____ **County:** _____

Years in 4-H: _____ **Name of 4-H Club:** _____

Name of 4-H Leader: _____

Project start date: _____ **Project end date:** _____

How many years have you had a harness goat project? _____

Revised March 2009

This book is a compilation of guidebooks and record books prepared by:

Ohio State University Cooperative Extension

Robert K. Troutman, Wayne County Extension Agent, 4-H

Paul Ickes, Wayne County 4-H Advisor

Bev Wittenmyer, Wayne County 4-H Advisor

Michigan State University Cooperative Extension and Dept. of Animal Science

Beverly and Mickeylouise Myers, goat producers

Cornell Cooperative Extension

Lynn A. O'Brien, Allegany County Extension Educator. 4-H

tatiana Stanton, Goat Extension Associate, Cornell University Dept. of Animal Science



Cornell University
Cooperative Extension

Table of Contents

1. YOUR PROJECT RECORDS	Page 1
2. BASIC CARE AND INFORMATION	Page 7
3. EQUIPMENT NEEDED FOR DRIVING A GOAT	Page 16
4. TRAINING YOU GOAT TO DRIVE	Page 26
5. SHOWING A HARNESS GOAT	Page 29
6. MICHIGAN GUIDEBOOK TO DRIVING GOATS	Page 43

Project Goals for 4-H Harness Goat Project

Name of Animal: _____ Year: _____

Training Goals:

Dates	Goals
Start Date	
Date Accomplished	
Start Date	
Date Accomplished	
Start Date	
Date Accomplished	
Start Date	
Date Accomplished	
Start Date	
Date Accomplished	

Other Goals:

Dates	Goals
Start Date	
Date Accomplished	
Start Date	
Date Accomplished	

PROJECT SUMMARY

Approximately how much time did caring for your harness kid or goat take you every day? _____

What took the most time?

How did you finance your project?

What was the most exciting new thing you learned to do?

What difficulties, if any, did you have with this project?

What did you enjoy most about your project?

What changes would you like to make next year and/or what changes did you make this year compared to previous years to make your project better or more enjoyable?

What public presentations, talks, articles, fieldtrips, or workshops did you participate in or present to your club, school, community, or the general public:

What things would you like to see your 4-H group do next year?

The Goat Halter and Harness

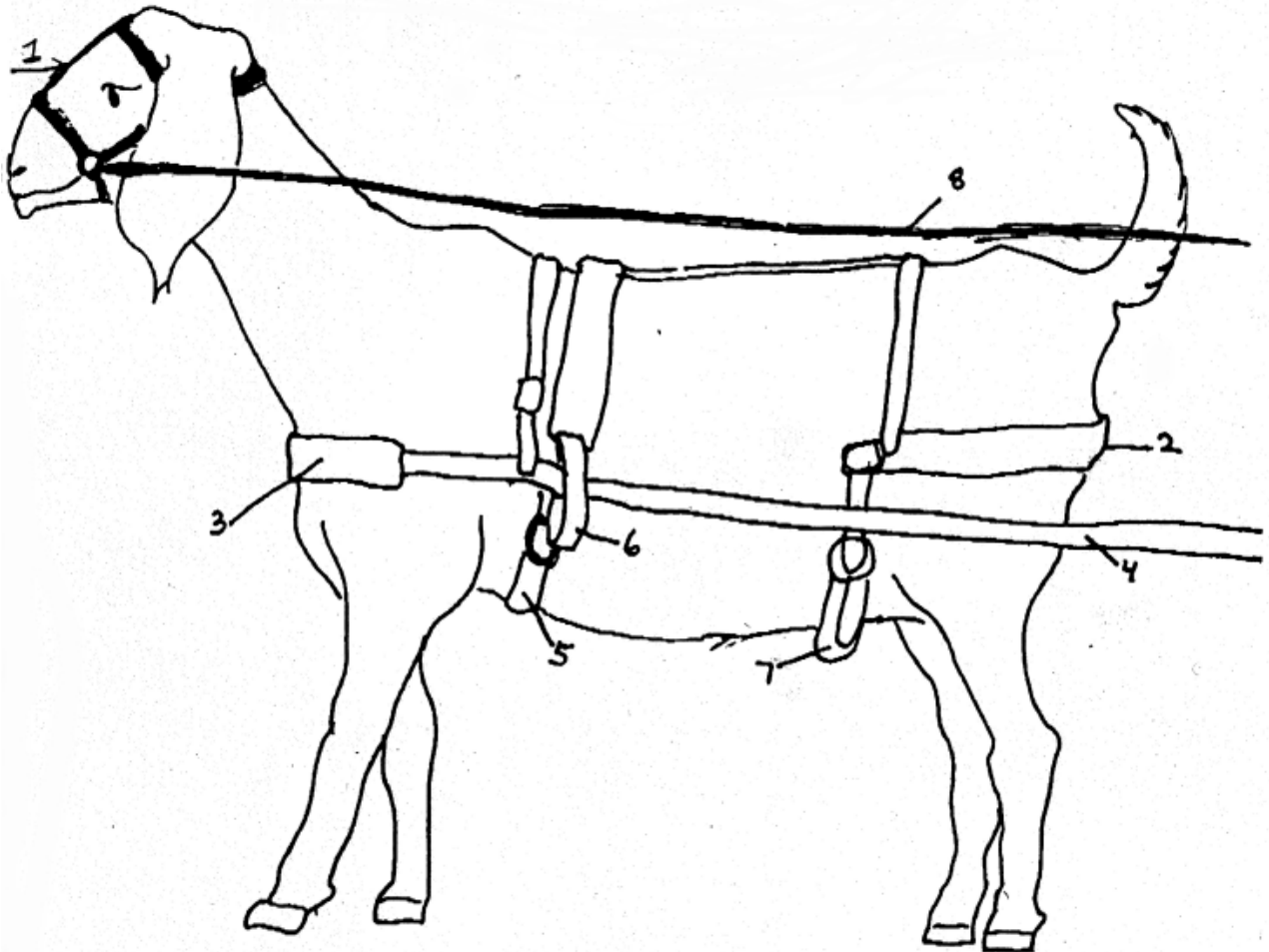

- 1 - BRIDLE 2 - BREECHING 3 - BREASTCOLLAR 4 - TRACE
5 - SURCINGLE 6 - SHAFT LOOP 7 - BREECHING STRAP 8 - LINE

Prepared for 1993 Caprine Outing held at Watkins Glen, NY, April 30-May 2, 1993,
by Debi Tullar, "Country Kids" Allegany County 4-H Goat Club. Halter and Harness
designed by Lynn O'Brien, County Extension Agent.

GETTING STARTED ON YOUR HARNESS GOAT PROJECT

The purpose of the 4-H Harness Goat Project is to help 4-H club members gain knowledge and understanding in 1) selecting a cart goat, 2) learning to drive a goat, 3) learning to train, manage and show their own cart goat and 3) keeping records to evaluate their project. In addition, 4-H members enrolled in this project will have the opportunity to experience ownership responsibility, develop leadership ability and learn how to work cooperatively with others in achieving individual and group objectives.

Guidelines

Before a member enrolls in the 4-H Harness Goat Project, they must make a personal commitment to see the project through. It will involve a lot of time, but the rewards can be many.

This project is designed to take a maximum of three years to complete. During the first year, the member will usually select or purchase a young goat and train it to be shown in a halter or on a lead. During the second year the member will train their young goat to pull a cart and depending on its age and size may start to add a driver. During the third year, the member will train their goat to pull both a cart and driver.

Definition of Terms

- A purebred goat is one whose parents are both of the same breed. A crossbred goat is the result of mating a purebred doe of one breed, such as a Nubian, with a purebred buck of another breed, such as Boer
- A grade goat has at least some unknown ancestors in its immediate pedigree.
- Registered or recorded - A purebred animal registered with a recognized breed or registry association or a grade goat that is recorded with a registry association
- Castration – to neuter a male goat
- Kid - A young goat from birth to under a year of age
- Yearling – A young goat from the age of one to less than two years old
- Horn bud or button - The small growth on the poll from which the horn develops
- Disbudding – to burn the horn buds when a kid is young (3 days to 3 weeks – the sooner the better) so that the goat will not grow horns
- Polled – an animal that is born naturally hornless. You will feel no horn buds when you rub their poll
- Doe - Female goat
- Buck - Male goat
- Wether - Castrated male goat

The Goat as a 4-H Project

Goats make excellent 4-H projects. Their size and outgoing personality make them ideal companions that are easy for youth to handle and care for. Young people can learn more about many of nature's processes by experiencing the daily care and management of their project goat.

Some Considerations in Raising Goats

Daily Responsibilities - A goat, like all farm animals, is a creature of habit. Be sure you have the time to give your animal regular daily care before you decide to raise one or you will be disappointed in the results.

Town Regulations- Find out if you live in an area where animals can be raised. Some towns have strict zoning regulations.

Space Requirements- Will there be adequate housing or room to erect other buildings, should your project expand? Is there land enough to have an outside paddock and possibly a pasture or browse area for your goat to graze in? If you have pastures and hay fields to produce your own forage, these can really help cut down feed costs. Otherwise, make sure you are willing to commit to buying hay on a regular basis for your cart goat. You will also need to provide the goat with trace mineral salts. Young, growing goats will usually require some daily concentrates in order to grow at an optimum rate.

Basic Information

Selection of Your Goat

It is sometimes best for beginners to start with a kid which is no more than eight to twelve weeks old. This will give you the opportunity to get acquainted with your goat and its habits as it grows up. However, a well behaved yearling or mature goat may also suit you and will allow you to start driving your goat sooner.

Your main considerations in selecting a potential driving goat are health, conformation, temperament and size. Select an animal of a breed you like. However, remember that you will want an animal that be big enough to pull you and your cart when it grows up. Goats of large sized dairy or meat goat breeds are probably best for this purpose. Miniature goats, Spanish goats, Tennessee Meat goats, Fainting goats and Angora goats are all smaller breeds and will often need to be managed as pairs in order to pull a cart and rider.

Since you are not buying a production animal, it can be a purebred, crossbred or a good grade. Male goats tend to be larger than female goats of the same breed which is advantageous in a

cart goat. However, bucks can be difficult to control and strong smelling especially during the breeding season and should therefore be avoided. They are also not permitted at some 4-H shows. A castrated male goat (wether) has the size of a buck without the strong odor and generally has a far calmer and gentler temperament. Wethers are usually less expensive to buy than females even if they are purebred.

You want to estimate how large the goat is likely to be as an adult. Looking at the goat's parents can help you determine how big the goat is likely to get and also give you an idea of how calm a temperament it is likely to have. Ideally, you are hoping your goat will mature to be at least 35 inches or taller at the withers with a mature weight of 175 pounds or more.

Recognizing Good Conformation

Study the outline of a goat on the next page. Learn the names of the different parts of the animal and their comparative importance in judging animals. After becoming familiar with the parts of the goat, you will be in a much better position to know what type of animal you are selecting: good, very good, or excellent. Even though you might be selecting a wether, your points of selection will be similar to selecting a goat for production purposes.

There should be some width to the floor of the chest so the front legs will not be too close together. Width plus the depth of the body denotes lung capacity and general health. Good body stature is associated with strength and ruggedness.

The goat should walk effortlessly and freely suggesting that it has sound feet and legs that will have no problem pulling a cart on a regular basis. When viewed from the front, the front legs should be fairly straight rather than obviously toeing in or out. Hind legs should look relatively straight when viewed from the back. If the hind feet are not perfectly straight when viewed from the rear it is actually better for them to toe out slightly (or the hocks to point in) rather than for the feet to toe in (or the hocks to point out). The two toes of each hoof should sit close together rather than being splayed apart. The hooves should be well trimmed so the feet do not become deformed. Knees should exhibit no puffiness or swelling.

The hind legs should show some bending at the hocks so that the leg does not look "posty" or "straight as a fence post" when viewed from the side. The pasterns should also have a little angle to them rather than being perfectly straight. However, if the pasterns are too long they are likely to become weak as the animal. Eventually they can become so weak that the dewclaws may rest on the ground as the goat walks. Posty legs and weak pasterns result in too much strain on a

goat's hocks and stifle joints and make it easier for the goat to "break down in its hind end" and become lame as it gets older. You want your cart goat's legs to last for many years so that your goat will have a long, useful life!

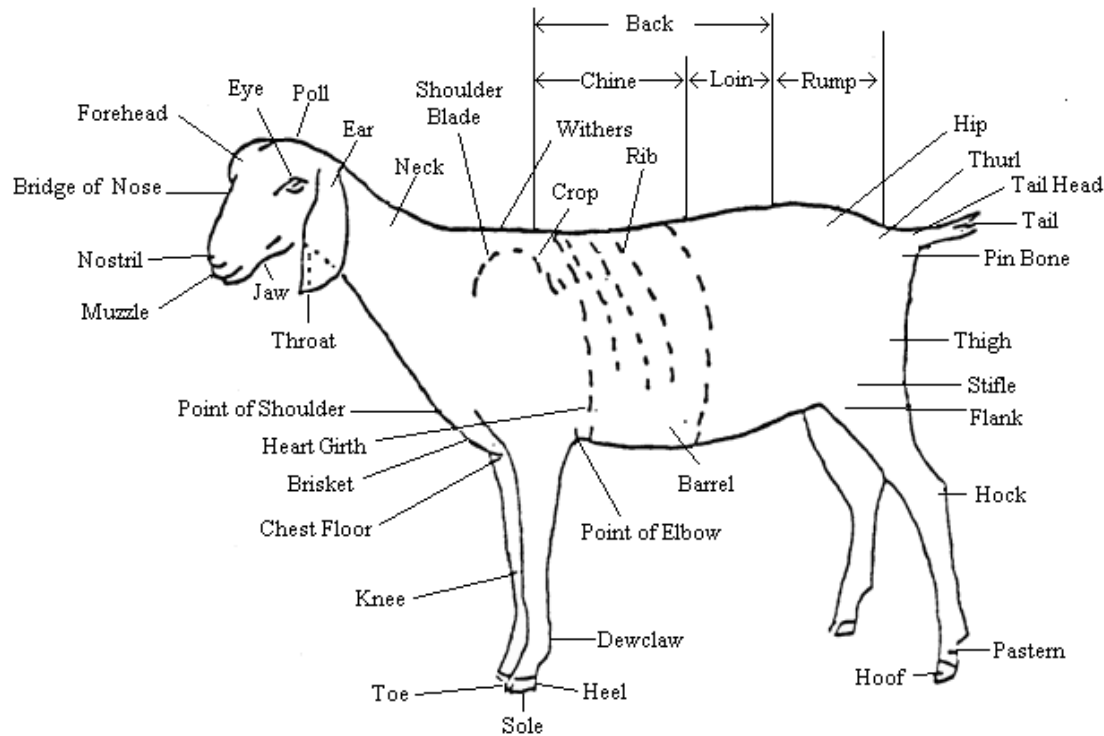

The skin of the goat should be smooth, thick, and pliable. The hair should be reasonably fine to denote quality, but this will vary considerably with the breed. The head of the goat should have an alert intelligent appearance with the ears and head the shape of its particular breed.

Dehorning

Keep in mind that some goats are born naturally polled and will not need disbudding in order to grow no horns. However, this is the rare exception. Most goats will grow horns and you will be able to feel their horn buds erupting within a few days of birth. It is a good idea to disbud a potential cart goat within about 3 to 10 days of age or as soon as the horn buttons appear. This involves using a dehorning iron or dehorning paste to burn off the horn buds. Using an electric dehorning iron is the preferred choice because dehorning paste is very caustic and can cause blindness if it gets into the goat's eyes and nonelectric irons require a hot fire in order to stay hot enough to do a good job burning the horns. An experienced goat raiser can disbud a kid at as late as 3 to 4 weeks of age but "scurs" will often result. Scurs are small weak horns that will need to be

clipped regularly with a pair of hoof trimmers or pruning shears to keep them from interfering with the goat's driving halter. It is best to disbud a kid early!

If the goat was not disbudded as a young kid you will need to decide whether to leave the goat horned or have a veterinarian dehorn it for you. Once the horn buds get too large they can no longer be burnt off. Instead the whole horn must be surgically removed. This is a very painful operation and requires that the animal be sedated. Because two holes into the sinus cavity result, it should be done far ahead of fly season to allow plenty of time for the holes to heal over. If you decide to leave the goat horned, keep in mind that some 4-H shows do not permit horned goats to participate. You will need to handle a horned goat with care. When you bend over to fit the harness onto a horned goat, always stay very alert because the goat may accidentally hit you especially when it tosses back its head to fend off flies.

Castration

Male goats develop a strong musky odor during the breeding season. They tend to pee on their beards and do other unappetizing activities during the breeding season. Therefore most male goats used for recreational activities like driving and packing should be castrated. The earlier the male kids are castrated (have the testicles removed), the less shock to the animal. However, some people believe that it may be better to wait until the goat is 2 to 4 months old so that his urethra (the tube taking urine from his bladder to the opening in his penis) has plenty of time to mature possibly resulting in less chance of the goat developing urinary calculi.

Urinary calculi is a potentially deadly condition that occurs when mineral deposits or "stones" develop in the goat's urinary tract and block the flow of urine. If the stones are not removed or dissolved, the goat's bladder will burst, resulting in death. Luckily, the diet and care of a goat have much more of an effect on whether a goat will get urinary calculi than how old a goat is when it is castrated. Male goats that get plenty of exercise, clean good quality water, and salt are far less likely to get urinary calculi. Female goats rarely, if ever, get it. If a wether is fed concentrates, the concentrates should be balanced to provide 2 parts of Calcium to every 1 part of Phosphorous. If the goat is being fed concentrates on a daily basis, it is usually recommended that the concentrates contain ammonium chloride or that the goat's water contains an acidifier such as Acid Pak 4-Way 2X Alltech® to help prevent the formation of urinary stones.

There are three methods that can be used to castrate your goat. The New York State 4-H factsheet, "All about castrating and urinary calculi" outlines all three methods and tells more about

preventing urinary calculi. It is available on the web at the Cornell Youth Goat Extension web site, <http://www.ansci.cornell.edu/4H/goats>. There is also a slide show there for one of the common methods. Some of these methods can only be used on the kid while it is still very young. Most experienced goat raisers are skilled at doing at least one of these methods on kids. Keep in mind that the younger the kid is, the less pain there will be. If the goat is mature, it will need to be sedated for the castration and you will probably need to have your veterinarian do it.

Health

When you buy a goat, take an experienced goat raiser with you. Find out if the farm has any contagious diseases that you will not want to bring to your own place. Some diseases to ask about are foot rot or foot scald, CL Abscesses (also known as Caseous Lymphadenitis or Corynebacterium), and sore mouth. Ask about the “Caprine Arthritis Encephalitis” status of the herd. This disease is spread primarily through the milk so kids that are fed bulk milk from a bunch of does in the herd are more likely to get it than kids that are fed pasteurized milk or only drink from their own dams (mothers). One of the common signs of CAE are swollen or arthritic knees so be sure to check the knees of the dam of a kid. Be sure to find out what vaccinations the kid and its dam have already had and the types of feed and amounts the kid is already started on. Ask if you can take a little of the feed with you to use on your kid for the first few days. Try to make new changes in feed gradually. If you are reserving a kid while it is still young enough to disbud ask if the owner is willing to disbud it for you. Also check whether they can castrate it for you.

Once you get the kid home, the most serious health risks tend to be scours, overeating disease, tetanus, pneumonia, and worms. It is best to discuss these possible health problems with your veterinarian and plan how to prevent and treat them. Have your veterinarian or 4-H leader teach you how to take a temperature with a rectal thermometer. Have them teach you to check a kid for dehydration by pinching its skin and seeing how rapidly the skin goes back in place and to check for anemia by pulling down their lower eyelid and checking whether the tissue on the membrane on the inside of the eyelid is getting pale. Find out what vaccines your kid needs.

Kids, especially those on a milk replacer, are susceptible to scours (diarrhea). Mild scours can be treated with Pepto-Bismol or similar medications. Part of the kid’s milk or milk replacer can be replaced with an electrolyte solution to help replenish the fluids it is losing and keep the kid from getting dehydrated. A commercial electrolyte solution can be used or if none is available some people follow the following protocol: Mix in one gallon water, one tablespoon salt, and one

tablespoon baking soda. Feed the mixture for 12 hours in an amount equivalent to the milk replacer that had been being fed. Then replace $\frac{1}{2}$ the mixture with milk replacer for the next day or two. If the condition persists or if the kid shows any sign of dehydration or weakness be sure to immediately contact your veterinarian. Severe diarrhea may require antibiotics to help control the bacteria causing the diarrhea.

Overeating disease or enterotoxemia is caused by a bacterial build up of the lower gut. These bacteria are commonly called Clostridium C & D. They produce a toxin which is fatal. Luckily, there is a vaccine to help prevent this disease. However, even in vaccinated kids it is important that you carefully regulate the feed intake of your kid and do not make sudden increases in the amount of milk or concentrate you provide. Instead be sure to make all increases in feed gradual. Kids that are being castrated or disbudded are at risk of being exposed to tetanus bacteria. Luckily, there is also a vaccine for tetanus. Normally, the mother goat is vaccinated for tetanus and enterotoxemia about 4 to 6 weeks before her kids are born and this vaccine protects the kids until they are old enough to get their own boosters at 8 and 12 weeks of age. However, check with your veterinarian or 4-H leader about the best time to give these vaccines. In many state, goats (just like dogs) need to be vaccinated for rabies before they can be exhibited at public events. A sheep vaccine is used. It can not be given until the kid is about 3 $\frac{1}{2}$ months old.

To avoid pneumonia, keep young kids from getting wet and protect them from drafts. They can withstand cold weather but drafts are dangerous. Poor ventilation can also lead to pneumonia even in older goats. When you squat down at your goat's level what does your goat's stall smell like? If it is difficult for you to breathe because the stall smells so much like urine then the ventilation in your barn is probably poor or it may be time to re-bed your goat's pen. Common signs of pneumonia are refusing feed, rapid or congested breathing and temperatures $\geq 104^{\circ}\text{F}$. The normal temperature of a goat is about 102°F . When these symptoms are present you should contact a veterinarian for assistance. The veterinarian will usually start the kid on an effective antibiotic.

Kids can become infected with internal parasites such as worms or coccidia whenever they eat off the ground or close to fecal material. Try to keep your mangers and waterers free of feces. If possible, avoid letting your kid graze where older goats or sheep have already been grazing that year. If your kid starts to show any of the following symptoms: weight loss, anemia, rough coat,

and/or scours, have a sample of their droppings examined by a veterinarian. If they have internal parasites, treat according to their recommendations.

External parasites, such as lice, ticks, and flies, are also harmful to your goat. Brushing your goat regularly will help eliminate the long winter hair that lice like to live in. There are commercial dusts that you can purchase to help control lice and ticks. You can reduce the fly problem with good sanitation. Get rid of manure, heaps of rotting vegetation and garbage. Follow directions carefully if using insecticides.

Remember that it is not normal for a goat to “go off feed”. If your goat loses its appetite contact your veterinarian immediately.

Hoof Trimming

Animals housed on soft moist bedding away from cement and asphalt yards, ledges, and rocks have less wear on their hooves and will need hoof trimming regularly. Unless feet are kept properly trimmed, a foot can become deformed. Foot bones thrown out of line by lack of hoof care can cause an animal to go lame and may mean the shortening of an animal’s productive life. When the weather and ground are dry, hooves will tend to get very dry and more difficult to cut. It is always easier to trim hooves regularly rather than letting them get too long and having a really hard job. Check the hooves once monthly and trim as needed with a pair of hoof trimmers designed for sheep or goats. A knife can be used but is more dangerous. However, both trimmers and knives have sharp edges so be sure to handle them with care. Some people like to use a wood planer to put the finishing touches on their trimming job. Always trim your goats feet no closer than a week to ten days prior to a show or exhibit. This way if you accidentally trim the hooves too short the goat will have plenty of time to recover and not be lame at the event.

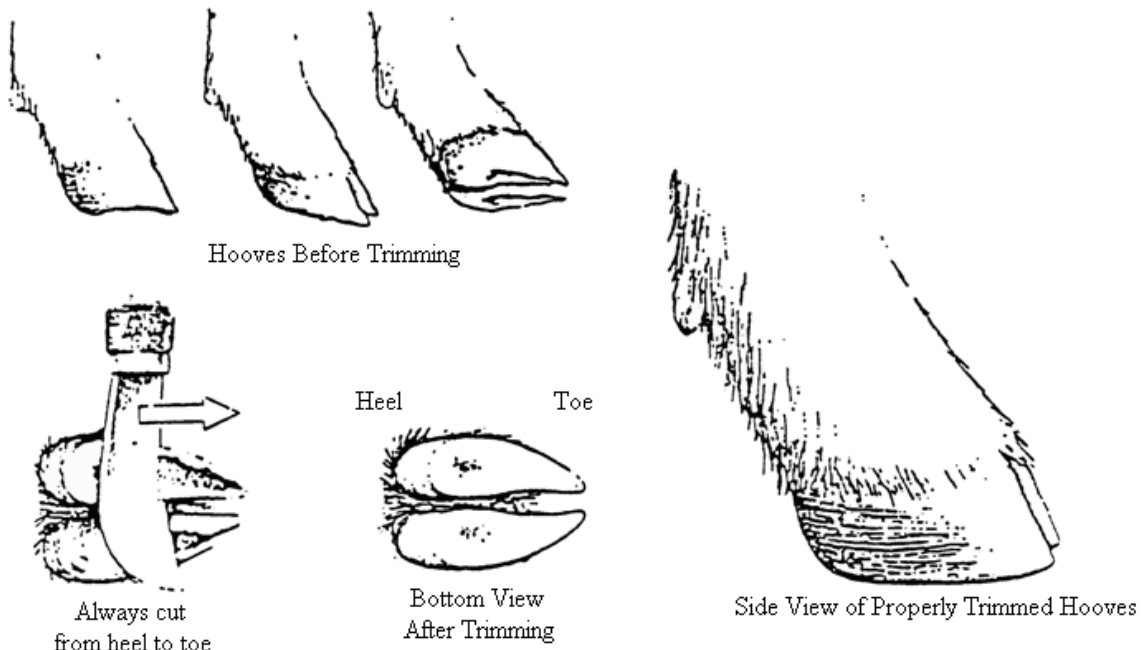

Feeding Your Goat

Goat kids require good quality hay. The hay can be either a grass or legume hay or a mixture of both but should be of good nutritional value. The nutritional quality of most hays drop when the plants are harvested at a mature stage. You want your hay to be full of legume leaves or grass blades rather than having lots of mature stems or seed heads. Mature stems will usually be thick and brittle while immature stems will be thin and flexible. The hay should smell nice and have no signs of mold.

Goat kids usually need daily concentrates as well while they are rapidly growing. Talk to your 4-H leader about a good concentrate to provide for your kid and about how much of this feed you should provide each day. Most kids will only require from $\frac{1}{4}$ to 1 lb of concentrate daily while growing depending on the quality of their hay or pasture. When you first start giving your kid concentrate feed only offer a small amount of it per day. Gradually increase it to your target amount. Remember to follow the rules to prevent urinary calculi.

Even though it is a good idea to provide concentrates to kids while they are growing, harness goats are at risk of getting fat once they approach their mature size. Fat goats will have more stress on their legs and will be more difficult to keep in shape. They are also at more risk of urinary calculi. Therefore, it is often best to keep mature harness goats off grain completely unless you are working them really hard. You can usually limit their diet to hay and/or pasture with small pieces of carrots or apple as your treats. This is assuming that your harness goat is not a pregnant or milking female. These does will need increased nutrition just like any other doe in their condition. It is best to avoid driving pregnant does during the last 6 weeks of their pregnancy.

Getting ready to show

Prior to going to a show you may need additional bedding to keep your goat clean and avoid stains. Regular leading and posing several weeks prior to the show day will prove very helpful when competing in showmanship contests. Brushing and hand work every day for several weeks prior to the show will improve the quality of hide and hair. Hoof trimming and bathing are needed to make the animal look its best. One to four weeks before show date, weather permitting, hair clipping is done at the discretion of the exhibitor, and may be used to present the goat at its best advantage. It's a good idea to give your goat a bath the day before the show and on show day wash the tail web, nostrils, hoofs, and any stains. Wipe off their teeth to clean off any food that is trapped on them.

Introduction to Having a Cart and Driving a Goat – Robert K. Troutman

The problem of finding a use for surplus kids faces many goat owners. It is obviously a step to increased profit when these kids can be utilized. A driving goat may be the answer.

There is fun as well as utility in having a cart and driving a goat. It can be top notch advertising too. Beyond that there is real opportunity for cashing in on driving goats.

As a pet, a goat is not surpassed even by a dog. Children love a well trained goat that can pull them around in a cart. For light hauling jobs, even pulling a garden cultivator, a goat can more than pay his way around your home. If the cart has a neat advertisement for the dairy goat painted on it, it is immediately a highly effective medium for drawing attention of the public to the dairy goat. Placed in line at public parades and celebrations the inexpensive goat cart, drawn by an attractive goat, may well outshine the expensive floats of others. Driving a goat cart around at a fair can really help focus attention on the goat exhibits there.

The Halter

A bit in the mouth is not necessary to train a goat to pull a cart. Many people find a simple halter will do the job. Goat halters or miniature horse halters are readily available or you can make your own. All that is needed is a strap around the nose, one on each side of the head, and one around the head behind the ears. A buckle on the one behind the ears is necessary to remove the halter. A ring fastened to the nose strap is where the driving lines are fastened with a snap on each side of the head. The driving lines can be made of long straps with a snap on one end.

The Harness

A harness made of rope or string will work, but a nylon or leather harness is much better. It can be made at home at a small cost or by a harness maker for much more. Seat belt material also makes a very strong harness. There are several parts to the harness which all have a purpose. The first and most important is the breast strap. This strap extends around the breast of the animal and is actually the part that moves the cart. Therefore, this part should be wider and stronger than the rest of the harness. Second is the chest strap. This strap must have a buckle so the harness can be removed easily.

Next are the traces (if used) and the rump strap which extends back both sides of the animal and around the rump. This strap is connected to the breast and chest straps at the front

shoulders of the animal and prevents the harness from sliding forward when stopping. A small strap over the back of the animal (near the rump) is necessary to keep this strap in place.

At the point where the breast and chest straps cross, a short strap with a buckle should be fastened to the harness. This is where the shafts of the cart are connected. This will carry the weight of the shafts and pull the cart. This strap should be designed to fasten to the shafts securely.

All of these harness straps should be made adjustable to allow for growth of the animal. They should fit fairly loose to allow the animal to walk freely.

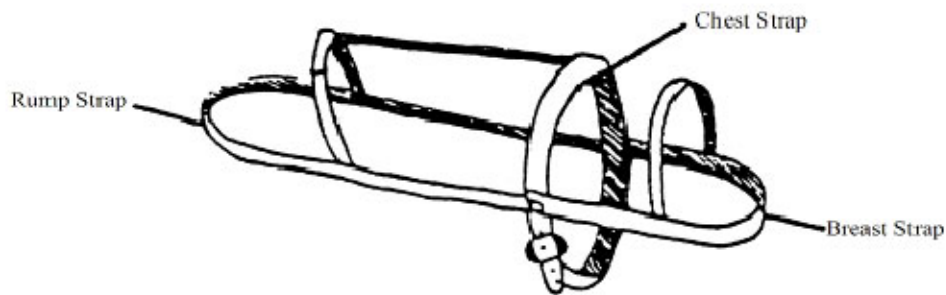

Building the Cart

Your cart can be built from many inexpensive materials which you may already have. Three parts are needed, the seat or box, the shafts, and the wheels.

The box or seat can be made of plywood or simply pine boards with the wheels or axle fastened directly to it. The only size restriction is that the width should be approximately 36 inches wide to prevent tipping. Otherwise the seat can be made any size or shape that suits your own personal plans.

The wheels then can be fastened directly onto the seat or box or with an axle extending under this section. The most convenient wheels to use are 20 inch bicycle wheels. They can be found in anyone's garage or backyard at very low cost and are very simple to adapt to the cart. They can be bolted directly to the seat or connected by the axle under the seat. Either method will do the job.

Unlike most pony carts, your goat cart does not need tracers to pull it. It can be pulled directly by the shafts connected to the harness. The shafts can be made of broom handles connected directly to the sides of the seat. More sophisticated shafts can be made but are much more expensive and not necessary for a goat cart.

A few things should be kept in mind when building your goat cart. The cart should be made of lightweight materials and its size should match your animal's size. The wheels and shaft should be positioned to give the cart a good center of balance. The wheels should turn freely and the overall appearance of the cart should be made attractive.

Below is a simple cart and the materials needed to build it. This is just an example and need not be followed. Your own plans and materials can be used to build a suitable cart (detailed plans for a cart are included on page 25).

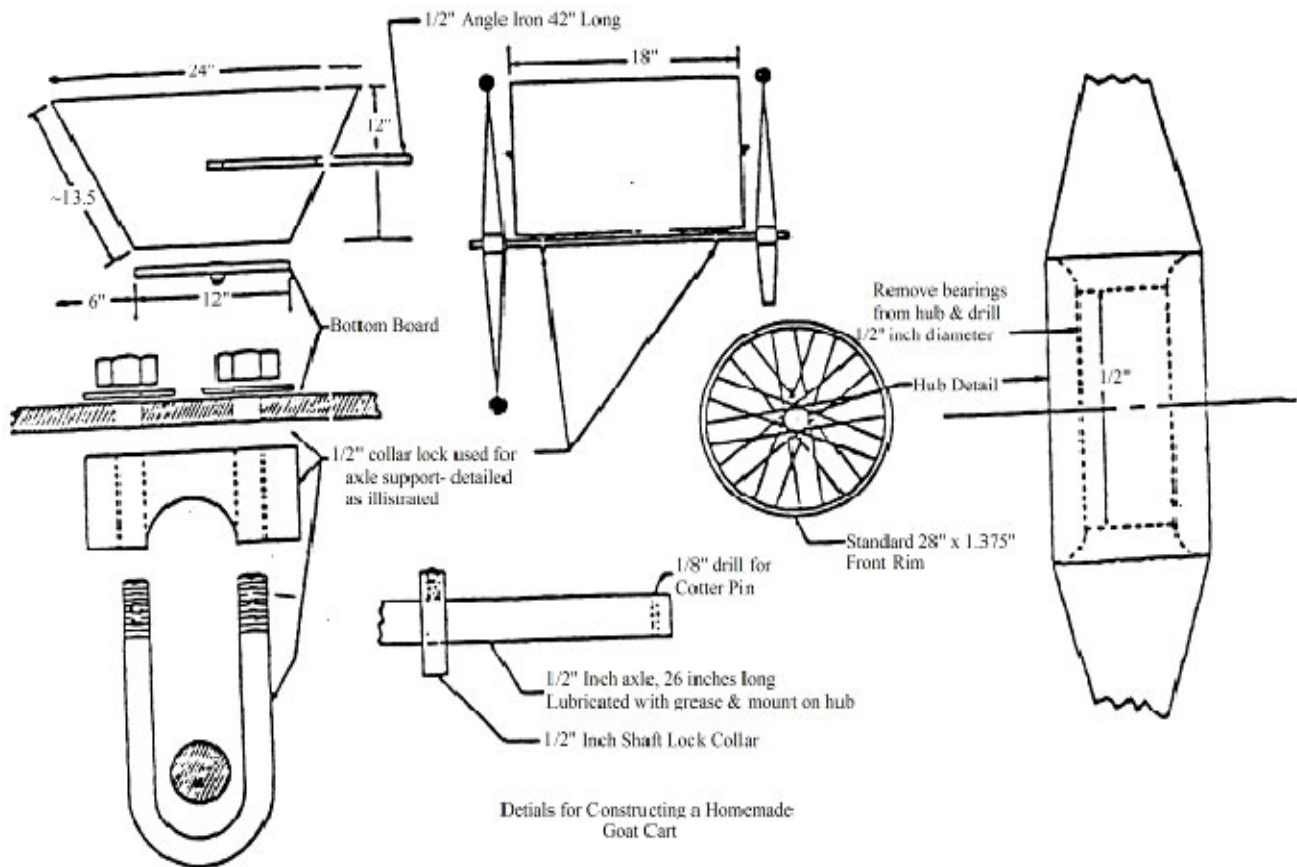

Harness and Halter

According to Georgia Wilkerson, Bushnell, Florida, “Anyone who can nail a board and sew can make a goat cart and harness.” She used lawn chair webbing to make the harness, and halter for her large Nubian buck, which “goes in all the parades in the area.” She used the following material for her buck’s halter and harness:

- 1 Two-inch buckle
- 1 Half-inch buckle
- 8 Eyelets
- 3 One-inch black rings
- 2 Snaps
- 2 Half-inch rings with one flat side

Small roll of two inch webbing

10 feet Half-inch flat nylon rope

¼ yard Fabric, for padding

Georgia cautioned to measure the goat before constructing the halter and harness. The harness must fit the goat snugly, she said, but not tightly (See Figure 1). If it is too big, overlap the material and sew a big X on the overlap, “But, if it’s too small, you’ll have to start over again.”

She starts by making the strap that fits over the withers and around the heart girth (A), as all the straps are sewn to it. She cuts a strap 86 inches long out of the two-inch webbing for her Nubian. Fold the strap in half; it is now 43 inches long.

Then she cuts a piece of fabric 43 inches long and two inches wide. Sew the fabric and webbing together along the edges. The fabric padding will be next to the goat. Attach the buckle to one end of the strap by overlapping the material and sewing. At the other end of the strap, put four eyelets. Put the strap on the goat with the buckle under the front legs, Georgia said. Pin in at the point of the shoulders (B) and the top of the withers (C).

Next, the breast strap (D) must be made. Cut 60 inches of the two-inch webbing and fold it in half so it is 30 inches long. Cut a piece of fabric 30 inches long and two inches wide, sew it to the webbing. Sew this strap to the heart girth strap at the point of the shoulders.

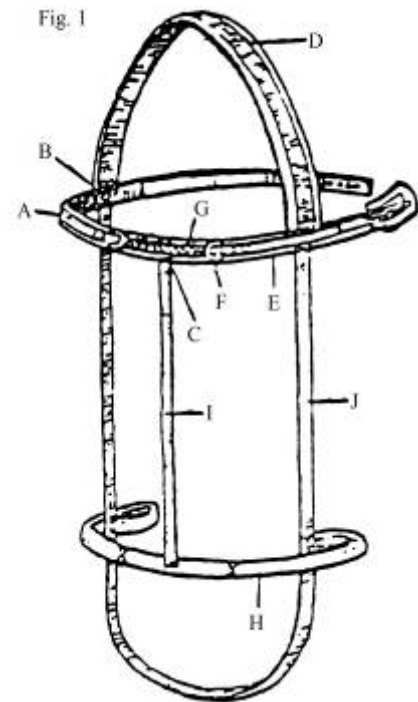

To make the straps that hold the cart (E), Georgia cuts a 36-inch strap from the half-inch flat nylon rope. Fold the strap in half, and then attach this piece to the heart girth strap at the top of the withers. Sew the two straps together for 10 inches in the center of the cart strap. Put the flat side rings (F) close to the ends of the sewn material. Sew the snaps at the end of the cart strap.

Georgia cuts eight inches of the half-inch nylon rope and sews it to the heart girth strap in front of the center of the breast strap. This piece (G) holds the reins that go through the loops to the halter.

Cut one 16-inch strap and another 26-inch strap from the half-inch nylon rope. Sew three-inch loops at the ends of the 26-inch strap (H). In the middle of the piece, sew one end of the 16-inch strap to the point of the withers on the heart girth strap. (Be sure it is not on the same side as the breast strap.)

Cut 72 inches of the half-inch nylon rope (J). Georgia sews one end on the heart girth strap across from one edge of the breast strap. Loop this piece through the openings of the 26-inch strap, and sew the other end across from the other edge of the breast strap.

While Georgia successfully uses a harness made of webbing, the Myers and Troutman believe a leather harness is best. Troutman does say that rope or string may be used to construct the harness, while the Myers' second is a leather and webbing harness. They also said a standard

Shetland pony harness will fit a goat, needing only minor alterations.

Georgia does not use a bit. (See Figure II). She makes a halter by cutting two 12-inch pieces of half-inch nylon rope (A). Then she sews one end of one strap to a second ring. She loops the third ring through the second strap so it is free. Sew the ends of the second strap to the first two rings.

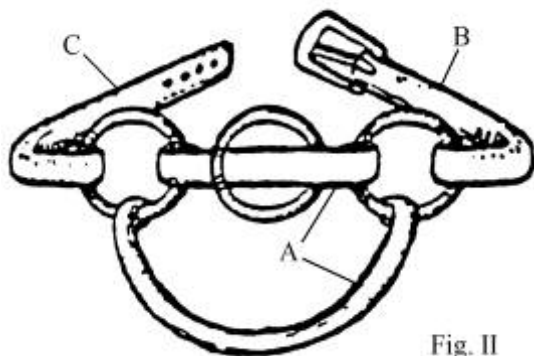

Fig. II

Cut 11 inches of half-inch nylon rope (B), Georgia said. Sew one end of it to one of the end rings with a three-inch overlap. At the other end, sew the half-inch buckle. Cut a 22-inch piece (C) from the half-inch nylon rope. Sew it to the other end ring. At the other end of this strap, put four eyelets. This strap goes up and over the head to fasten the buckle.

All that is needed to complete Georgia's harness and halter are two long straps for reins.

More on Building a Cart

The type of cart you build depends on its purpose and the materials on hand. If you're going to use the cart for hauling, it needn't be as attractive as the one used for parades, but it will need to be soundly constructed.

Jerry Belanger, Dairy Goat Guide publisher, made a cart for his son a number of years ago. (Honestly, he admitted, his father built it.) "The result," he said, "is a beautiful little cart which is easily pulled by a goat, making heads turn and traffic stop."

Old 30-inch bicycle tires were used for wheels, and "elegantly curved pieces of oak" (braces from an old piano) were used as fils (shafts). Jerry said, "There are many ways such a cart could be built. When you design your own, you're limited only by your imagination." His father used these materials for the cart:

From half-inch plywood, cut:

- 2 30 x 9-inch pieces (sides)
- 2 15 x 9-inch pieces (front and back)
- 1 30 x 16-inch piece (floor)
- 2 9 x 16-inch pieces (seat and backrest)
- 2 9 x 9-inch pieces (salt sides)
- 1 16 x 19-inch piece (underframe)
- 4 (2 x 4s), 9 inches long (braces)
- 2 $\frac{3}{4}$ x 3 x 24-inch pieces of wood (underframe)
- 4 $\frac{3}{4}$ -inch angle irons, 30 inches long (frame)
- 2 $\frac{1}{4}$ x 1 $\frac{1}{4}$ x 25-inch pieces of iron (for bracing fils to wagon box)
- 2 $\frac{1}{4}$ x 1 $\frac{1}{4}$ x 5-inch pieces of iron (for bracing fils to wagon box)
- 2 screw eyes, assorted nuts, bolts, washers and hardware

After removing the brake from the rear bicycle wheel, the wheels were fastened to the angle iron. The plywood underframe was bolted to the iron, with a notch cut out to accommodate the wheel axles. The two pieces of $\frac{3}{4}$ x 3 x 24-inch board were then bolted near the ends of the iron frames, raising the actual floor of the box above the axles.

This cart had fenders, which were made by soaking strips of $\frac{1}{4}$ -inch plywood, then bending them to the desired shape to fit the curve of the wheel. They were fastened to pieces of half-inch

board cut slightly larger than the diameter of the wheel, and then the whole assembly was bolted to the box.

Country side publications' staff also designed a goat cart to be used for hauling. (See Figure III) It can be changed to suit your needs and built from scrap material. Made as drawn, 3/4-inch plywood is used. The bottom is a solid piece of plywood with notches cut out for the wheels and fenders. The two pieces of 1-inch angle iron for each wheel are mounted to the bottom sheet of plywood.

The fenders are a sheet of metal that is fastened to a piece of plywood which has been made four inches larger than the wheels. The fender is then fastened to the side of the cart. Turn under the outside edge of the sheet metal for safety.

The positioning of the fenders and braces and the length of the fenders depend on the size of your goat. These measurements can be determined during construction.

The body of the cart is braced by 2 x 4s at the corners and by 2 x 2s on the inside at the floor. The tail gate is hinged at the bottom and latched on the inside of both sides. Sideboards covers with chicken wire may be added to the cart when hauling light, bulky items such as loose hay leaves.

Your cart-trained goat can be a real helper around the farm. And this summer, when the parade's in town, your helper can be a star.



Instructions for Building a Goat Cart

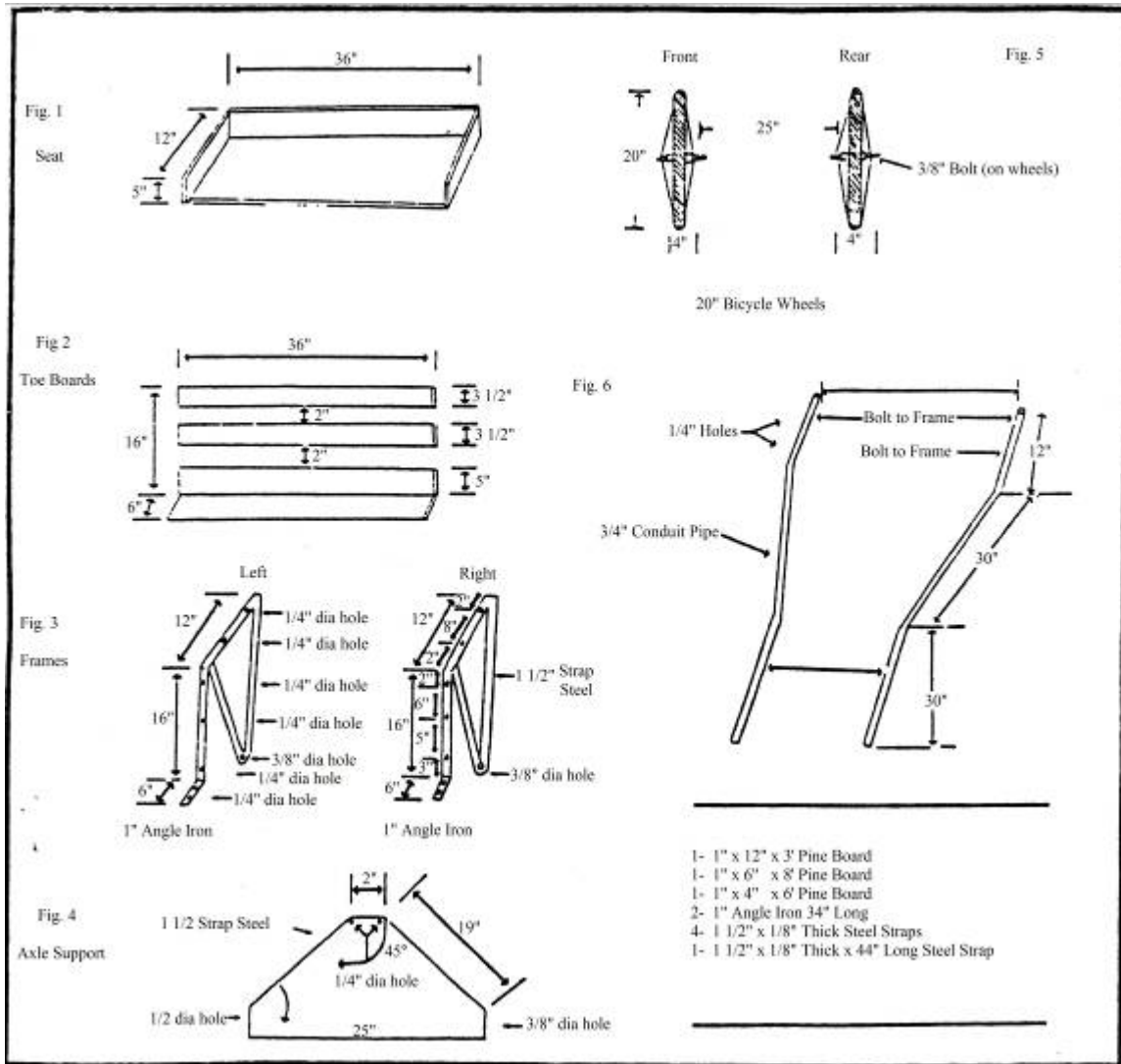

- Fig. 1 Step 1- Cut 3 ft. pine board to exactly 3 feet – be certain ends are square.
 Step 2- Cut 8 ft. board into 3 pieces – measuring two 12 1/4” pieces and a 36” piece.
 Step 3- Glue and nail 36” piece to 1 edge of seat board (3 ft. pine board).
 Step 4- Glue and nail 12 1/4” pieces to each end of the seat board making sure tops and ends are flush.
- Fig. 2 Step 1- Cut one 1”x6”x6’ board into two equal 36” pieces.
 Step 2- Cut one 1”x4”x6’ pine board into two 36” pieces.
- Fig. 3 Step 1- Mark steel angles at 12” from one end. At this point cut a 1/4” pie shaped piece out of one side of angle. Bend angle at this point to close cut at approximately a 15° angle.
 Step 2- At opposite end of angle measure 6 inches and cut off with hack saw. Retain this piece to be welded later to frame for toe board support.
- Fig. 3 Step 3- Drill a 3/8” hole 1/2” from one end in each 1 1/2” steel strap

- Step 4- Put strap in pairs of two and insert 3/8" spare bolt in hole and secure with nut finger tight.
 - Step 5- Spread other ends of steel straps apart and position on 12" end of main frame as in Fig 3
 - Step 6- Bolt or weld straps to main frame in this position.
 - Step 7- Repeat Steps 1-6 for right hand frame, bending angle iron so angles are opposite each other with steel straps on inside of main frame (angle iron).
 - Step 8- Bend approximately 15° angle so that end of main frame at cut end is exactly 10 1/2" from 3/8" bolt in strap.
 - Step 9- Weld pie cut in this position.
 - Step 10- Then weld toe support (6" piece) onto front of frame parallel to top frame rail.
 - Step 11- Repeat steps 8, 9, and 10 on right frame.
 - Step 12- Drill holes in both frames as shown in Fig. 3
- Fig. 4 Step 1- Bend 44" long steel strap to dimensions shown in Fig. 4 forming axle supports.
- Step 2- Drill holes in axle support as shown in Fig. 3.
- Fig. 5 Step 1- Obtain two 20" x 1.75 bicycle wheels. Note that rear wheel (with brake) has wider axle than front. This should be used for right wheel of cart.
- Step 2- Retain nuts with wheel axles for later use.
- Fig. 6 Step 1- Bend conduit pipe as shown in Fig. 6.
- Step 2- Drill frame holes in conduit pipe in 12" end (to secure to frame) as shown in Fig. 6.
- Fig. 7 Step 1- Assemble cart. Turn seat board bottom side up. Position right and left frames on bottom of seat in 3/4" from each end with toe board at front of seat. Make certain frames are parallel with ends of seat.
- Step 2- Using 1/4" diameter drill; drill holes as shown in Fig. 7.
- Step 3- Using four 1/4" carriage bolts, bolt seat to frame with smooth head of bolt in seat.
- Step 4- Position two 3 1/2" toe boards on front of frame. Using 1/4" diameter drill, drill holes as shown in Fig. 7 and bolt toe boards to frame using four 1/4" carriage bolts (smooth heads out).
- Step 5- Position one 6" board on toe board frame. Drill holes as shown in Fig. 7 and secure boards to frame.
- Step 6- Install other 6" board on edge above the board and bolt in this position as shown in Fig. 7.

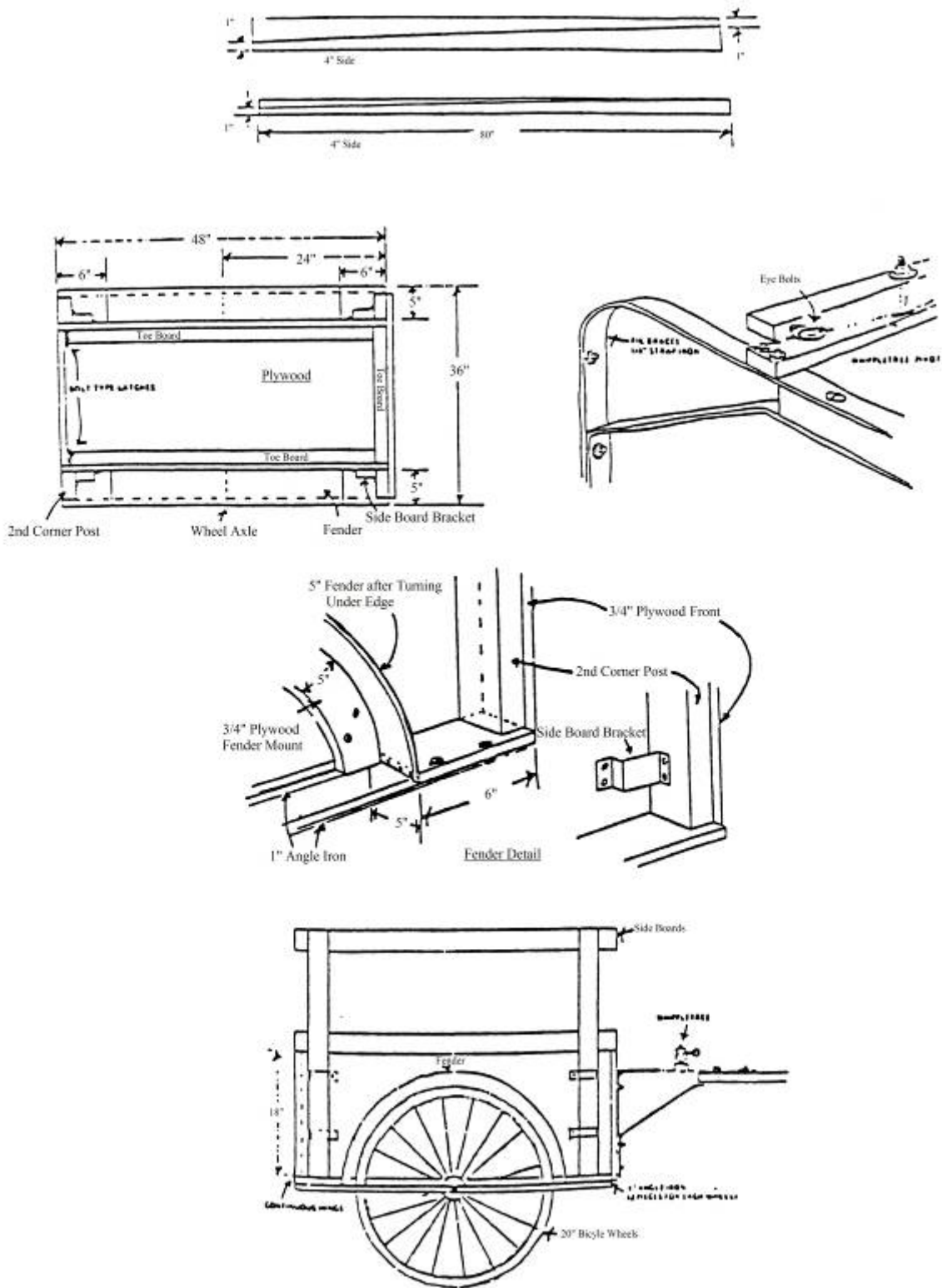
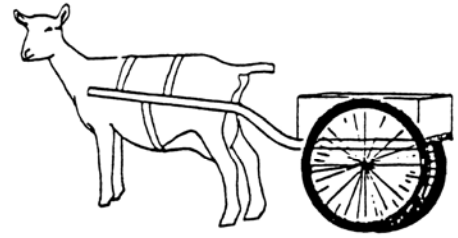

Fig. 7

Training a Goat to Drive – Robert Troutman

Selecting your animal is the first step in successfully training a goat to drive. Two things should be considered when doing this. One, choose an animal from a large, strong family of animals, and two, choose an animal from a quiet, gentle family of animals.



First make sure that you have done a good job of training your kid to lead and stand. This early foundation will really help in future training. After you have made or purchased a harness and halter, put it on your animal and lead him around by the halter for at least one half hour twice a day. The best time to do this is just before feeding time. After you are done, feed the animal as a treat. Do this for two or three days before going to the next step.

Another important thing to do is use a few command words such as whoa, get-up and back-up. Speak loud and firm when saying these commands to your animal. Make him do what the command is each time you say that word. By the time he is pulling you in the cart, he will know what your command words mean and will do what you want.

When your goat doesn't mind having the harness on and walks normally with it on, you are ready for the cart. When you first attempt this, you should have another person help you. Slowly and gently attach the cart to your goat. Talking to him while doing this will help to keep him calm. Once he is hitched to the cart, lead him by the halter and have the helper walk behind the cart and steady it. Remember, if you have a runaway or crash at this point, don't give up! Remain quiet and be patient with your goat. He is only afraid and will soon learn you are not going to hurt him. Use the command words you have already taught him to get him to halt and move forward. Lead him around the yard where there are no trees or buildings as to prevent problems. Do this for at least 15 minutes each day for a week or so gradually increasing the time he spends pulling the cart to about a half an hour. When your goat becomes relaxed at pulling the cart and walking with you, let the lead rope out more and let him essentially walk beside you on his own. Now, you are ready to move on to the next step.

Have your helper lead your goat with you in the cart and holding the lines hooked to the halter. Talking to your goat constantly while doing this will help make your job much easier. Lead the goat around like this for several days and have your helper let go of the halter from time to

time and just walk beside the animal in case he tries to run away. Eventually, your helper can slowly walk away from the goat, and he will walk on his own with you behind him in the cart.

Another very important thing is to treat your animal to a small snack each time you are finished, or when he does what you ask him to do. Remember, you must have patience and work with your goat almost everyday until he learns what you want him to do. If you do this, in a few short weeks he will be pulling you around like he has done it all his life, and you will enjoy him more then ever. Again, gradually increase the time he spends pulling you. This will allow him to build up his muscles so that he does not become sore from overexertion.



Six Basic Wether Driving Steps – Gillian LaPoint
(Seneca County, New York 4-H)



1. Get acquainted with your goat. The better the relationship the easier the experience will be for both of you.
2. Familiarize your goat with a halter.
3. Leading:
 - Hook up lead line to the halter. Keep the goat on your right side at all times. Use crisp clear command, “walk” and give a tug on your lead. Use a series of “give and takes” which means pull your goat a few steps forward and then release and give him a treat (grain, carrots, apples, crackers or commercial “goat treats” make good treats). Once your goat has understood the “walk” command, move on to the next step.
 - Now that your goat understands the concept of the “walk” move of the other commands, which are “whoa”, “gee”, “ha”, and “trot”. Whoa, or stop, is an important command. Make sure to include this several times while practicing. “Gee” is the command to turn right, “Ha” means to turn left, use these commands while leading as well as driving. “Trot” is a pace just above the walk. To ask your goat to trot ask your goat to walk, then do a “give and take” while telling him to trot. If your goat still will not trot, ask a partner to help you by following behind the goat and lightly tap the goat with a short crop or stick while you tell him to trot. Once he trots be sure to reward him. When your goat understands these commands move to the next step.
4. With your assistant’s help, put on the driving harness. Make sure your assistant or help has a firm hold of your goat while you are putting on the harness. When the harness is secure, lead him around and practice all the commands. Make sure to emphasize stopping.
5. When your goat is comfortable with the harness, have your partner hold your goat while you put on the driving bridle or halter. Have your partner lead your goat while you follow behind, as if you were in a cart. At first let your partner give the commands. Then slowly take over, while at that same time your partner slides back at you. When you no longer need the assistance of your partner, unhook the lead and have your partner walk along side you. When you are able to perform all of the commands behind the goat, it is time to move on to the next step. This will usually take a few weeks.
6. With the help of your assistants (two helpers are ideal for this step) hook up the goat cart. Make sure everything is secure before proceeding. After the cart has been securely hooked up, have a helper hold your goat while you get in the cart. Once in the cart have the helper follow along side (still holding the lead line) while you give the commands. Again, make sure to practice “whoa”. When you feel comfortable, have your helper unhook the line and continue to practice with your helper walking next to the goat. Gradually have the helper step away and start practicing without a helper. Gradually introduce obstacles and hills.
7. Finished project - A well behaved, cart goat!

Showing your Harness Goat - Class Requirements

All harness projects must be secured by May 1 of the current year unless 4-H or fair rules stipulate different requirements. Harness goats cannot compete in market goat classes but may show in other classes for recreational goats and in showmanship classes that permit recreational goats. The goat may be leased or owned by the 4-H member. Clothing is at the exhibitor or fair's discretion. Unlike dairy goat competitions, white outfits are not preferred as they will show dust more. Sandals are not suitable footwear as they do not protect the member's feet well enough from cart wheels and goat hooves. The exhibitor is encouraged to have a helper standing by the edge of the show ring in order to prevent uncontrolled exit of the animal from the show ring. All harness goats must be tattooed or eartagged for identification purposes.

The Harness Goat Project is a multi-year project. Usually, during Year 1, the 4-H member takes their kid in the harness kid class. The second year the animal comes back as a harness yearling, and the third, and succeeding years, the goat is in the senior harness class. In addition to the following rules in the 4-H Advisors Guide, each harness pair (goat and handler) will be judged as they compete in the Harness Kid, Yearling or Senior competition. Only one pair will be allowed in the ring at a time for these competitions. The harness yearling and senior harness will have the option of starting at the edge of the show ring or being lead by a helper to the center of the show ring before the start of judging. The carts and harnesses will be judged on neatness and originality.

Harness Kid: He must be under a year of age. He must be halter broken and lead with a single lead strap. The project will be judged on the goat's response to the exhibitor's voice commands of stop, go, and back, along with the appearance of the animal and the exhibitor's appearance. The animal can be led through or over some obstacles similar to a beginning pack goat. In fact this class can be combined for both pack and harness kids.

Harness Yearling: He must be under two years of age and at least 8 months of age. **At the discretion of Cooperative Extension, the goat can also be a mature goat in his first year of training for driving.** The weight of the cart should be suitable to his age. He will be harnessed and pull an unoccupied cart driven by the exhibitor from behind the cart with the use of the reins, which are attached to the halter. The project will be judged upon the goat's response to the exhibitor's voice commands of stop, go, back, left, and right. The exhibitor's appearance, the

animal's appearance, and the overall neatness and originality of the cart and harness will also be considered. The animal can be taken through or over obstacles.

Senior Harness: He must be two years old or older. The goat will be harnessed and will pull a cart which is occupied and driven by the exhibitor through the use of the reins attached to the halter. The project will be judged upon the goat's response to the exhibitor's voice commands of stop, go, back, left, and right while going through an obstacle course. Judging will also include the appearance of the exhibitor, their goat, the cart, and the harness.

What the Judges Look For

As an exhibitor you should be neat and well groomed, sit up straight with your elbows in at your sides and your hands in line with your knees. Make the goat look alert but quiet. What the judge looks for varies with individuals, but basically the judge will examine the harness for its cleanliness, suppleness and fit. For example, the breast collar, should be neither too tight nor so large that it hangs loose, but should lie flat. Vehicles are checked not only for their appearance but for their size and suitability for the goat. Carts should be painted, clean, and in good repair. Two-wheeled and four-wheeled carts can show together. Your goat should be clean, well mannered, and appear to be healthy.

Group versus Individual Classes

In most cases, exhibitors will be judged individually rather than as a group and will come into the ring one by one to do an individual "course". The exception to this will be when goat kids are handled essentially as if they are competing in a recreational goat showmanship class or when the fair has a very large show ring and decides to add a "Driving Goat Pleasure Class".

Recreational Goat Showmanship Class

This class can be judged using the American Dairy Goat Showmanship Scorecard or a similar scorecard. The general rules are as follows:

- 1) Always move clockwise in the ring unless the judge tells you otherwise.
- 2) Lead your goat by his collar or halter at a normal pace with his head held high.
- 3) Keep your goat between you and the judge at all times. However, move in front of your goat when needing to switch sides.

- 4) When the judge changes your place, move forward out of the line up to the place you are directed to, go through the line, make a “U turn”, and move forward into line.
- 5) If your goat moves forward out of line, move it forward more to allow space for you to circle back through the line, make a “U turn” again and get back to your proper place.

Driving Goat Pleasure Class

This class requires a very large ring with rails to keep the audience from accidentally entering the ring. There should be handlers at the gate to help prevent uncontrolled exits. When showing in this class, all goats shall enter the ring at a walk. The goats shall go to the right and continue walking at will until ordered to change. At the discretion of the show superintendent, a period of not more than five minutes may be allowed for the class of goats to enter the ring. At the end of this period, no other goats shall be permitted to enter.

The entire class shall be worked at least once around the ring at a walk and a trot, then reversed in a figure eight, and worked at the discretion of the Judge in such a manner as he deems advisable. Goats shall be lined up after preliminary workout. They shall then be individually asked to back up. Goats should back up in a straight line. The judge may ask an exhibitor to work his goat around the ring individually, or he might call the exhibitors into the center of the ring one at a time. The goats shall line up properly and remain in the center of the ring until ordered out.

Judging will be done on a point system with the following points:

- | | |
|--|-----------|
| 1. Appearance of animal | 20 points |
| 2. Appearance of exhibitor | 20 points |
| 3. Overall appearance of cart and harness | 20 points |
| 4. Performance of animal in show ring (following commands) | 40 points |

Harness Goat
Project I

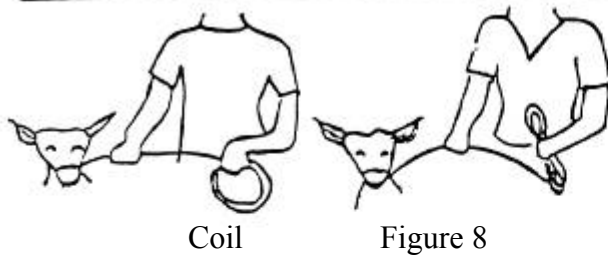

Hold the excess lead in your left hand wrapped in a coil or figure 8 fashion. Keep your hand near or against your belt.

Stance of Goat



Feet squared and goat should look alert

Showing and Judge's Examination

1)

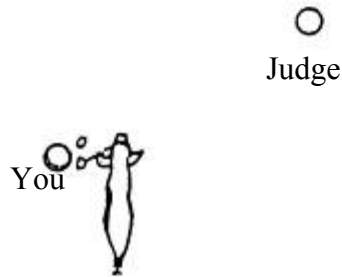

1) Face the goat when the judge is on the right. Stand with heels together and look proud.

2)



2) When the judge stands in front of your animal- face the judge and wait till he passes before changing sides.

3)

Judge



3) When the judge has passed, switch sides and resume position number 1.

Judging at Lead

Note: Do Not switch sides when at lead.

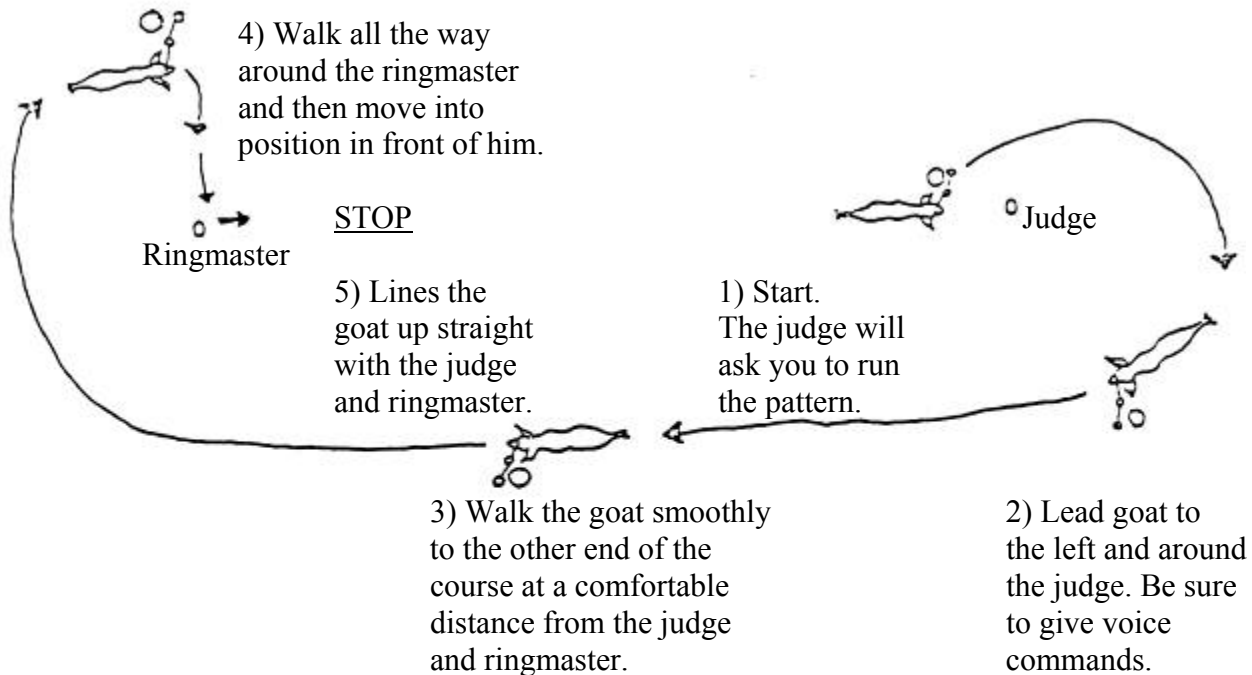

Judging Maneuverability

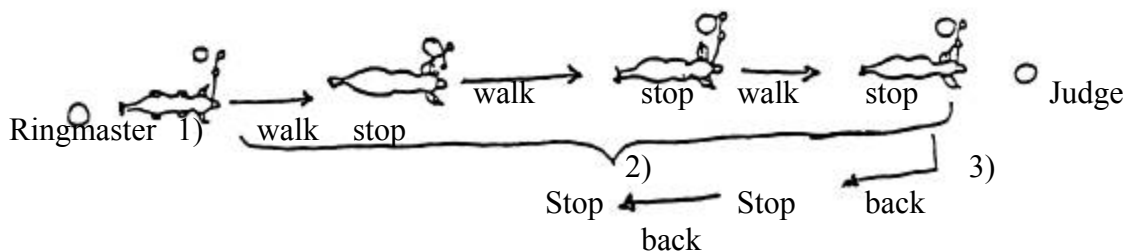

1) The goat's feet should be fairly square. If they are out of place try walking the goat forward a little. If they are still not correct use your hand to straighten them.

2) Walk and stop the goat three times. On the third stop, pause a moment and proceed with procedure 3.

3) Back and stop the goat 2 times. After you stop the second time, square the animal's feet and stand for inspection.

NOTE: The animal should lead calmly and willingly. The goat should not have to be tugged or pulled through the course. He should respond to voice commands.

Suggested Score Card – First Year

Appearance of animal 10 points

Appearance of exhibitor 10 points

Performance of animal and exhibitor 30 points

Comments:

Harness Goat
Yearling or Beginner

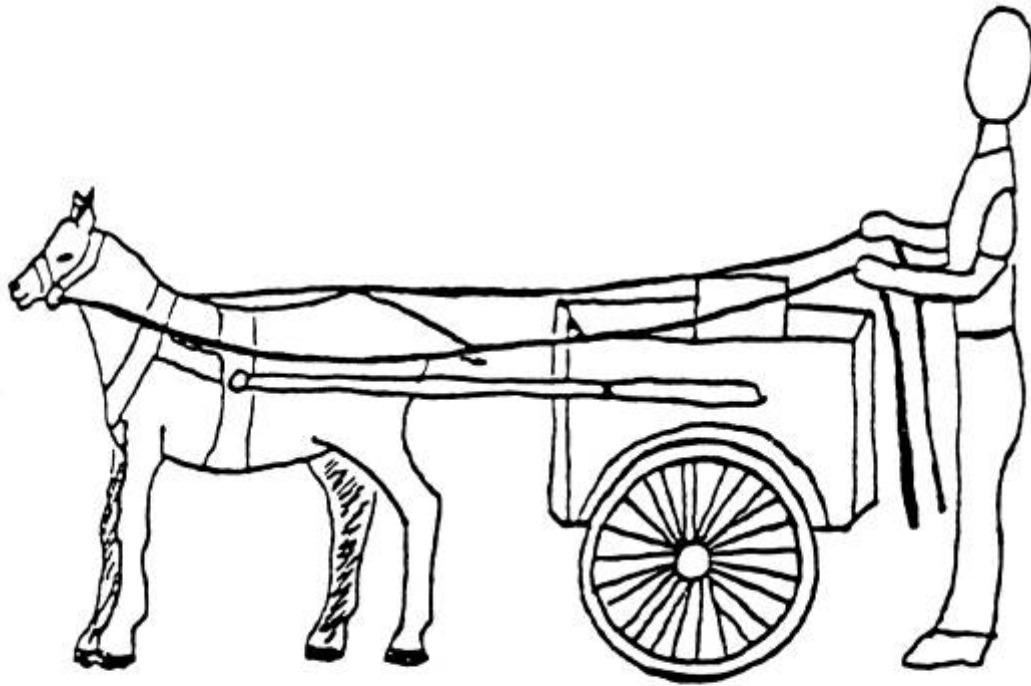
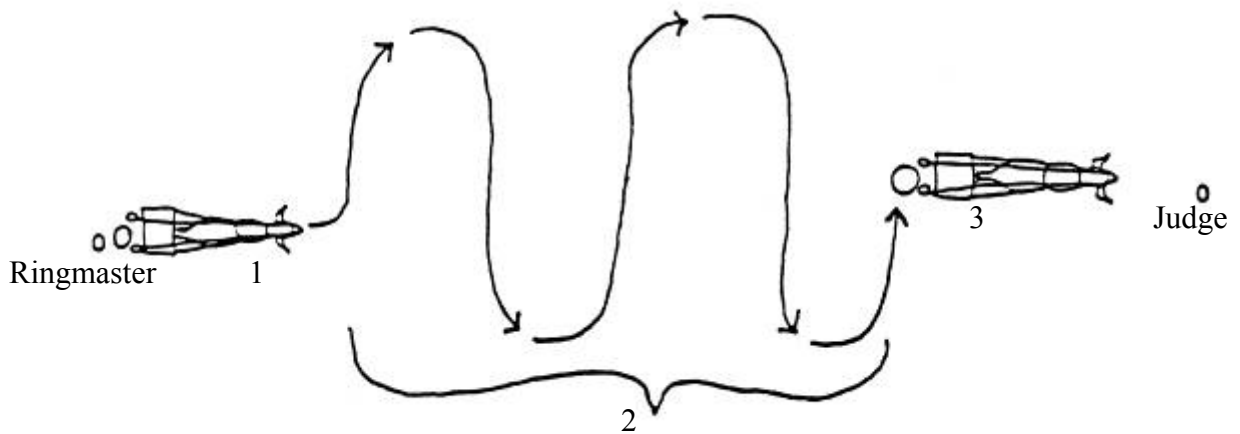

Figure 1

1) Proper Stance. You should stand with legs together. Stand tall with arms stretched comfortably in front holding the reins. The goat should look alert and its legs should be fairly square. The important factor is to establish and keep control of the goat at all times.

Yearling or Beginner Harness Project
Straight Line Pattern



1) Wait for the judges signal. Then begin serpentine pattern. Serpentine are loops that are the same size and demonstrate the goats driving ability. You are required to do three.

2) Serpentine should be smooth and all three should be the same or close to the same size. Don't forget to give voice and rein commands.

3) Stand for inspection and scoring before the judge. The judge will dismiss you.

Circle Pattern

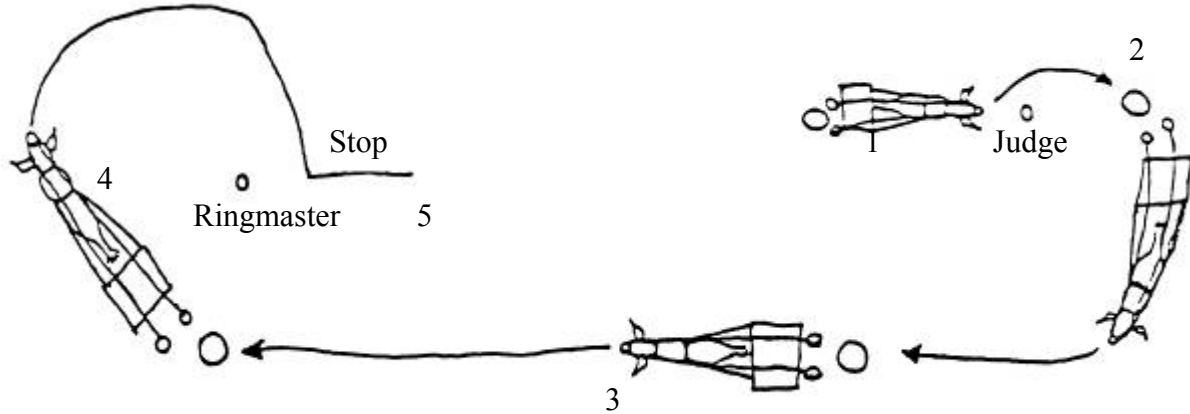

1) Stand before the judge in proper form. The judge will ask you to run the pattern.

2) Go left of the judge and around the back of the judge. Be sure to give voice commands to the goat when you are directing it.

3) Continue driving the goat to the other end of the arena to the ringmaster.

4) Continue behind the ringmaster. The goat should be pulling smoothly and responding to your direct commands.

5) Pull in front of the ringmaster so that the head of the goat is facing the judge. Try to be in fairly straight alignment with the judge and ringmaster. Stop and wait for the judge's hand signal to begin line pattern.

Yearling or Beginner Harness Project
Suggested Score Card – Yearling or Beginner

1 – 5 points for scoring.

Five is best score.

Circle Pattern

Scoring

- Proper stance when starting pattern. _____ 5 Points
 - Goat pulls cart smoothly and willingly. _____ 5 Points
 - Gives voice and rein commands. _____ 5 Points
 - Correct pattern and fairly straight alignment between judge and ringmaster. _____ 5 Points
-
-

Line Pattern

- The serpentines are smooth and close to the same size. _____ 5 Points
- Three loops are completed. _____ 5 Points
- Voice and rein commands are given. _____ 5 Points
- Goat responds to the commands. _____ 5 Points
- Person and goat in proper stance at completion of pattern. _____ 5 Points
- Person handled goat smoothly but firmly with pride. _____ 5 Points

(50 points) _____ Total

Comments:

Harness Goat
Third Year or Senior Project

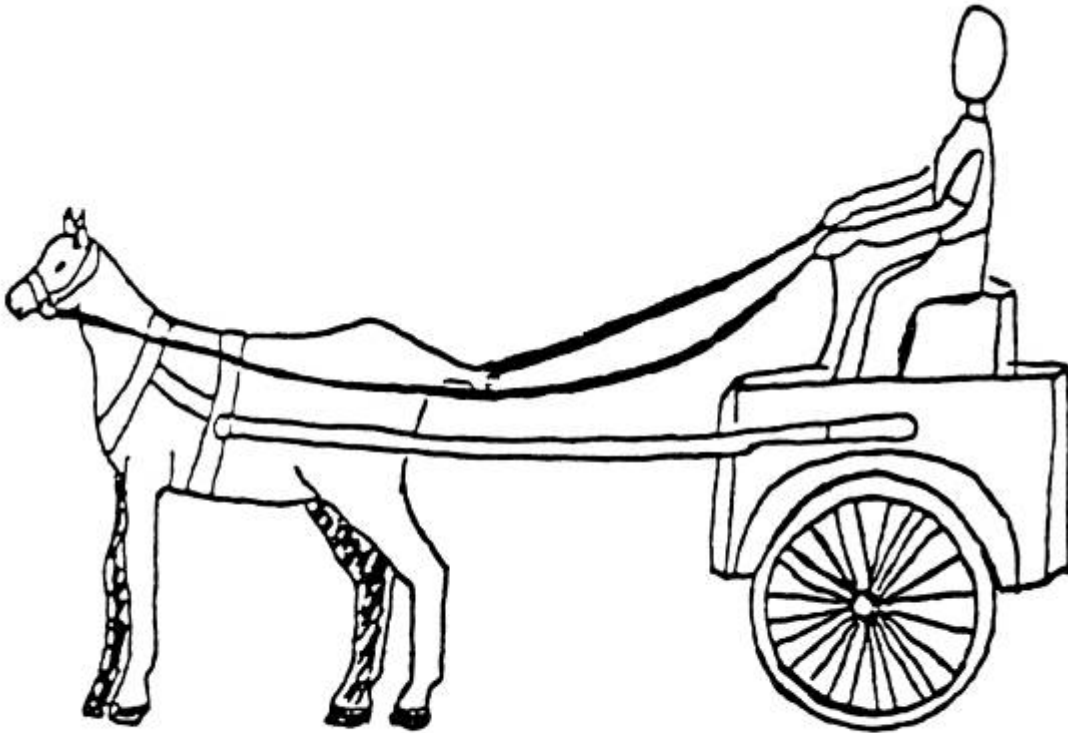
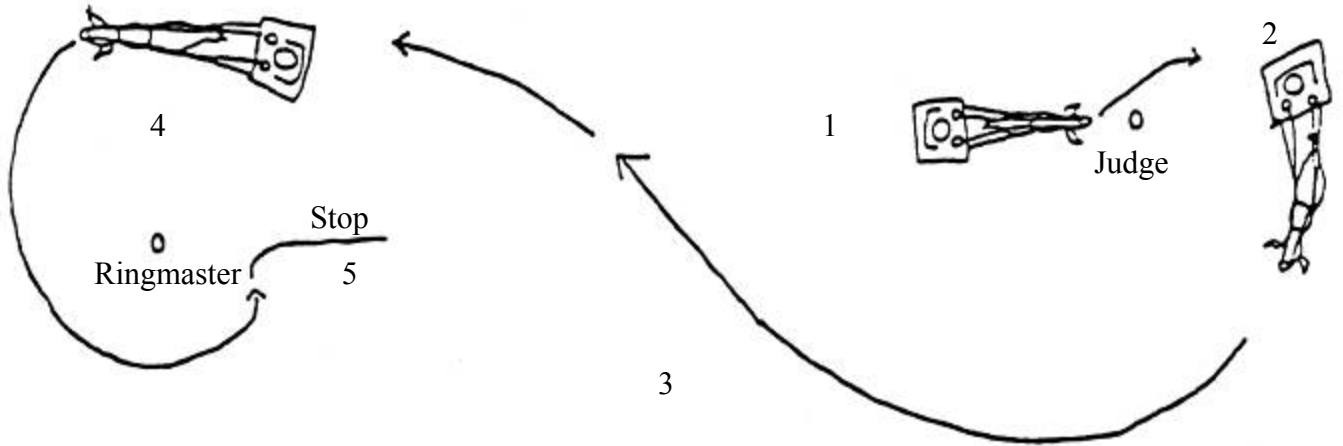

Figure 1

1) Proper Stance. You should sit erectly in the cart holding the reins comfortably, but firmly. The goat should look alert and feet should be fairly square. The important factor is to have good control over the animal at all times.

First Part



1) Stand before the judge in proper form. The judge will ask you to run the pattern.

2) Go left of the judge and around the back of the judge. Be sure to give vocal and rein commands to the goat.

3) Go through the center of the ring. You are attempting to make a figure eight. Your goat should drive smoothly.

4) Continue behind the ringmaster and to point 4.

5) Pull in front of the ringmaster so that the head of the goat is facing the judge. Stop and wait for the judges hand signal before starting second part.

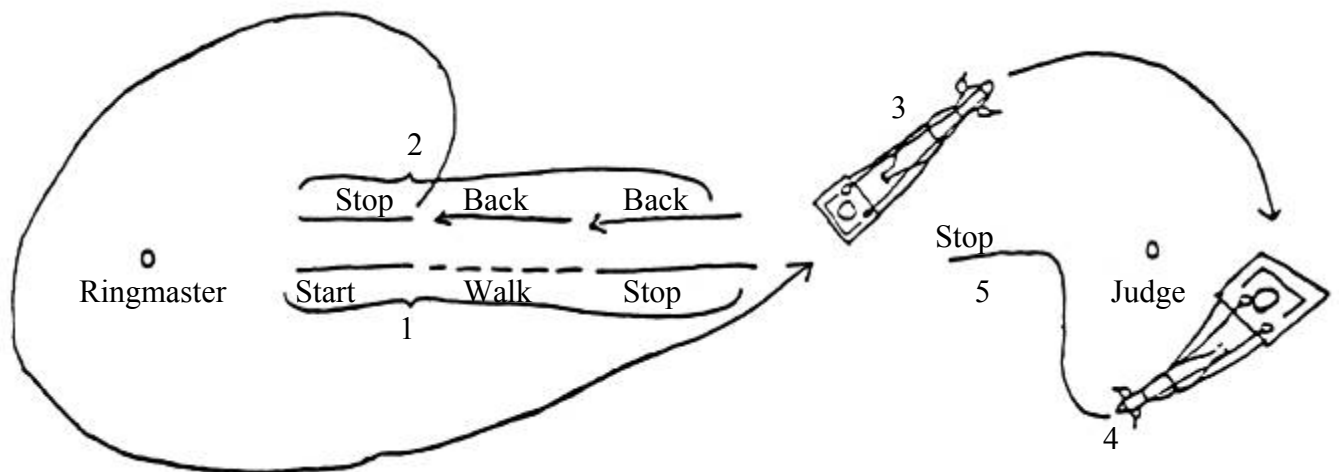
Second Part

1) After the judge's signal, walk forward to the center of the ring. Stop your goat.

2) Back your goat to the point at which you started in front of the ringmaster and stop.

3) Drive your goat to the left and proceed behind the ringmaster. Then continue to reverse the pattern through the middle of the ring.

4) Continue to walk all the way around the judge.

5) Walk the goat up to the judge, so that it is facing the judge. Stand for inspection.

All educational programs and activities conducted by Ohio Cooperative extension Service are available to all potential clientele on a non-discriminatory basis without regard to race, color, national origin, sex, handicap, or religious affiliation.

Senior Harness Project

Suggested Score Card – Third Year or Senior

1 – 5 points for scoring.

Five is best score.

First Part

Scoring

- Proper stance when starting pattern. _____ 5 Points
 - Goat pulls cart smoothly and willingly. _____ 5 Points
 - Gives voice and rein are given. _____ 5 Points
 - Correct first part and fairly straight between judge and ringmaster. _____ 5 Points
-
-

Backing

- Pulls to center before backing _____ 5 Points
 - Smooth, fairly straight _____ 5 Points
-
-

Second Part

- Reversing field with correct procedure. _____ 5 Points
- Person is maintaining control of the animal. _____ 5 Points
- The person drives the goat all the way around the judge before parking. _____ 5 Points
- Person handled goat with good ability and pride. _____ 5 Points

(50 points) _____ Total

Comments:

Driving Goats

Michigan State University Guidebook

By Beverly and Mickylouise Myers

Many of our grandparents remember the family goat that used not only for milk, but also driving. Many youngsters remember taking a ride on the goats back pretending it was a big horse like his big brother rode. Now goat driving is once again becoming popular across the country.

Many possibilities have been suggested for using harness goats. For many years they have been hitched singly or in teams to two-wheeled carts or four-wheeled wagons for children or farm work. Driving goats can be full of fun and pleasure; they can also be a working partner, and an ideal 4-H project. There is a growing market for trained driving wethers, and it seems to be a market well worth greater consideration.

Type of Goat to Use

Does are primarily dairy animals kept for their milk. They often make good driving goats although they lack the large size of bucks wethers. Their smaller size limits the weight they can pull.

Bucks have an offensive odor at times and can not always be depended on during breeding season. However a limited amount of work pulling a cart, cultivator, or other implement provides excellent exercise for the breeding male and helps him pay his way. Working and exercise also improves his temperament.

The best type of goat to use is a wether (castrated male). The larger the wether, the stronger he will be and the more weight he will be able to pull. Wethers are usually larger than does and can pull more than a doe. An ideal wether will be 36 to 38 inches high at the withers

(top of the shoulder). A large, full grown wether will weigh 250 pounds or more. If you are raising a driving wether, it is very important that you feed him well so that he grows fast, strong and big. A bottle fed wether should be frequently handled when he is young. He should be trained to lead early and treated gently so that he stays gentle and easy to work with. Always treat the goat gently but firmly, and he will be gentle. Treat your goat roughly or harshly and he will be rough. With patience and gentleness, goats are probably easier to train than horses and dogs. With care you will have a working harness animal that can hold his own in any company, and does full justice to his classification as a harness animal.

You can also start with a kid. Developing a standard harness goat is a fairly easy matter. Care in selecting the kid is about the only essential concern. The sire is important. Try to find a kid that has been sired by the largest buck in your area. The buck kid should be castrated as soon as possible. All kids intended for harness use should be handled constantly from an early age. At two months they should be collar-broken and taught to lead with a lead-line. By six months, the goats should be halter-broken, lead strap wise, and obeying voice signals of “whoa” “Get up” and “Back up”. At eight months the breaking harness should be gently placed upon the goats for very short times while the animals are in their stalls. They then become accustomed to the feel of the harness. If these simple steps are carefully followed, young goats can easily be trained to harness at 10 to 11 months of age.

Bridle and Harness

The parts of the harness and cart are defined at the end of this guidebook. There are also drawings there to help you identify these parts. The best and safest way to drive your goat is with a bridle that has a stiff-mouth or snaffle bit 3 to 3½ inch wide, with one inch rings. This

type of bit can be removed while the animal is resting or feeding without removing the entire bridle.

The harness can either be bought or made. We recommend buying adjustable harnesses to fit the size of your goat. Adjustable harnesses must either be made of all leather or of leather and web strap, with the leather used where adjustment buckles are located.

A standard small size Shetland pony harness will fit a goat. Some small changes such as removing the crupper will need to be made. Using the britchen is optional. A pony bridle will not fit on a goat's smaller more delicate head. Any animal, especially a harness goat, is entitled to good, comfortably fitting harness so he can perform his best. A harness goat must be trained and driven with a bit in his mouth for safe and efficient driving. Bridle, reins and harness must all be strong, since the power a standard harness goat can exert is truly surprising.

Carts

The vehicle pulled by a harness goat should be suitable. The cart should be balanced and the weight distributed evenly. It's remarkable how much a small wether can pull.

We have found that the ideal length of the fils (or shafts) is 44 inches long and 18 inches apart (wide) for a large wether. Fils fifteen inches apart at the tip are ideal when using a small wether. Remember that the cart should be easy to get into and out of for safety.

Training Your Goat

If you don't have a goat to start working with, look for a gentle, friendly, easy to handle, large wether if you can find one. If not, you may have a buck castrated. Give you goat about a week to get acquainted so that he becomes familiar with you and his new home. If you start with a goat kid aim to have him collar-broken, lead straps wise and obeying voice signals of 'whoa', 'get up', and 'back up' by about 2 months of age. At eight months, you can start

gently placing the breaking harness on your goat for very short times while he is in his pen. If these simple steps are carefully young goats can easily be trained to harness at 10 to 11 months of age.

As a first step take the bridle and put it on him for about an hour while he is in his pen. After doing this for a couple days, bring the harness to him let him smell of every piece of equipment before putting it on him. The first day put on the back pad and belly band. Walk him around for about 15 minutes. The second day put all the harness on with the reins connected. Reins with snaps can be added or taken off easier.

After several days of harnessing the goat, take the wether out with a lead rope connected to the bridle, and have someone else handle the reins at the rear. The reins should hang loosely and at the level of his back flank. Put the reins at this level to keep him from turning to face the driver. If he starts to turn you can gently pull the reins and he can feel them along his sides. Work him for only about 15 minutes at one time so he won't lose interest. You can repeat this lesson 2 to 3 times a day. As your goat progresses, you will no longer need a lead on the bridle. In time you should teach your goat to "Whoa" and "Back up". You might not want to do much backing up until you put your goat between the files (shafts).

You must be very careful on how you pull the reins. A goat has a very sensitive mouth. Too much hard pulling will give him sores in the corners of his mouth and his mouth will get tough and calloused. "Hard mouth" refers to an animal that does not respond to gentle pulls of the reins. A hard mouthed animal is also harder to manage. We always use a bridle and bit when driving our goats. Without a bit, we could not control a frightened animal. Safety, for both the goat and the driver, is very important.

After working with the goat for several days, he should walk along with you easily. It is now time to hook him to a cart. Remember, do not take a second step in training until your goat is comfortable with the first step.

1. Let the goat smell the cart. Something new and scary until your goat knows that it won't get hurt.
2. Hold your goat carefully. Have someone bring the cart up and move the fims (shafts) to the goats to the goat's sides.
3. Carefully rub the goat's sides with the fims. Gently move him from side to side. Let him feel the fims next to him.
4. Do not hook your goat up to the cart the first time. As long as the fims are loose, you can control your goat and drop the fims if he gets scared.
5. Be patient.
6. After the goat is very comfortable in the fims, you can start to walk the goat with the cart.
7. The first time with the cart, don't add any extra weight. Let the goat get used to the feel of something behind him.
8. Gradually begin to add weight to the cart, perhaps by leaning on it.

As soon as the goat moves forward easily in the cart, start training him to back up. Hitch the goat to the cart with someone standing behind with the reins and a second person at the goat's head. The headperson should hold the reins below the goat's chin and then use the other hand to push on the goat's shoulder while saying "back". Pull gently on the reins. With practice, the goat will back up with a gentle pull on the reins. Be sure to teach your goat to back in a straight line.

Safety is always important. When we harness a goat we tie the goat with a halter. The bridle is the last thing we put on our goat. The bridle goes on just before we put the goat in the traces. When we unhitch, we take our goat out of the files, take off the bridle, and put on a halter before taking off the rest of the harness. You and your goat can enjoy the experience more if you follow these simple steps to keep your goat quiet and controlled. **When participating in parades or driving on roads or public parking lots, use the same safety equipment that a horse and buggy or bicyclist would use: safety helmet, light reflectors, and elevated flags.**

Road Manners

Road manners are very important. Here are a few hints to help you train your goat to accept anything that might happen.

1. Introduce your goat to a wide variety of strange sights, sounds and places. If you plan to drive your goat in a parade, it helps to let the goat listen to marching band music beforehand several times. You might even want to take your goat to a marching band practice. A goat may be afraid of strange sounds, but once he is used to the sounds, he will ignore them. Other sounds like truck horns, chimes, and train whistles can also scare a goat.
2. Always watch what is happening. Try to anticipate anything that might scare your goat. A piece of paper blowing in the breeze, a child's noisy toy, an opening umbrella or a person running into the path may scare a goat.
3. Watch your goat's ears, they can tell you how he will react. If he is scared, try talking to him. Be prepared for anything.
4. When you are driving along a road for the first time, take along a second person who can jump off the cart and go to the goat's head to calm him.

5. Whenever you drive your cart, be sure your harness and cart are in good working order.

Check the reins, straps and traces on the harness. Check the wheels and wheel hubs to make sure everything is safe. Also be sure the harness is properly adjusted for the goat.

6. On the road give clear hand signals to let everyone know what you are doing and where you are going.

7. Never leave your goat while he is hitched to the cart. He might decide to lie down and get tangled in the traces.

Goat racing may sound like fun, but racing can be dangerous. An inexperienced driver or small child may try to drive your goat someday, and get hurt when your goat starts to run. If you are interested in racing, always do it with adult supervision and on a smooth, straight track.

A note about the authors: **Beverly Myers** and her daughter, **Mickeylouise Myers**, have driven goats for over ten years. In this guideline, they have shared their experiences and thoughts about driving goats. Mrs. Myers, an experienced 4-H Leader, highly recommends driving goats as a project for boys and girls who love animals, or for adults who enjoy new experiences. The artwork for this guideline was done by **Julie Drake**.

Many suggestions and recommendations in this guidebook are courtesy of the Dairy Goat Journal, Scottsdale, AZ.

Department of Animal Science
Michigan State University
East Lansing, MI 48824

TERMS USED FOR HARNESS GOAT EQUIPMENT

BACK STRAP - strap that goes around goat at the chine.

BELLY BAND - girth of band going under the goat's belly, immediately behind the front legs.

BIT - part of a bridle that goes in the goat's mouth, made of smooth metal, 3-3½ inches wide with one inch rings at the ends.

BLINDS - pads attached at an angle to the bridle to block rear vision.

BLIND BRIDLE - Bridle with blinders attached. A blinder is a piece of leather attached to the cheek strap behind the eyes to hide rear vision

BREAST COLLAR - Wide strap held in place across the animal's chest and used as major point for holding neck yoke in place.

BREECHING - rump straps, used as aid in backing up (optional).

BREECHING SEAT - strap attached to breeching that runs behind the goat.

BRIDLE - head part of a harness, used to hold back or control.

BROWBAND - band across goat's forehead above eyes that helps hold bridle in place

CHECK REIN - an adjustable line from the bit to the top of the goat's head and then to the saddle hook, used to keep the goat's head up.

CROWN - top of bridle over goat's head.

CRUPPER - strap attached to the back of a harness and passing under the goat's

FILS - shafts that run from cart along both sides of animal to pull and hold the cart.

FOUR-IN-HAND - two teams hooked together, one pair in front of the other.

GIRTH - strap or band that keeps the harness in place. It goes under the goat belly.

LINES - straps from bit to driver used to guide and control goat; reins.

LOIN STRAPS - strap runs over goat's back and attaches to breeching.

MARTINGALE - a strap of a harness that prevents the animal from rising on it's hind legs or throwing it's head back.

OPEN BRIDLE - bridle without blinds.

OVER CHECK - strap that runs from top of bridle to middle of saddle pad used to keep goat's head up.

PIPE-ENDS - end of fils or shafts.

REINS - a long narrow strap or line fastened to a bridle or bit, by which to guide or control an animal.

SADDLE - part of a harness that holds the shafts, or which a check rein is attached.

SADDLE HOOK - hook to which over check is attached.

SHADOW ROLL - a large sheepskin roll worn just above the nose and below the eyes to cut off goat's view of the road. Helps to prevent shying at shadows, pieces of paper or other objects.

SHAFT HOLDERS - strap on harness pad or saddle that holds the fils, often a loop.

SHAFT LOOPS - same as shaft holders

SNAFFLE BIT - metal bit built to move freely at the center.

SULKY - the two wheeled vehicle carrying the driver.

TANDEM - two goats hitched to a cart, one in front of the other.

TEAM - two goats hitched to a cart side by side.

TRACES - either of the two straps, ropes, or chains by which an animal pulls a wagon, carriage, etc.

TRACE SPREADER: bar that goes between the traces on lead goat in a tandem hook up,

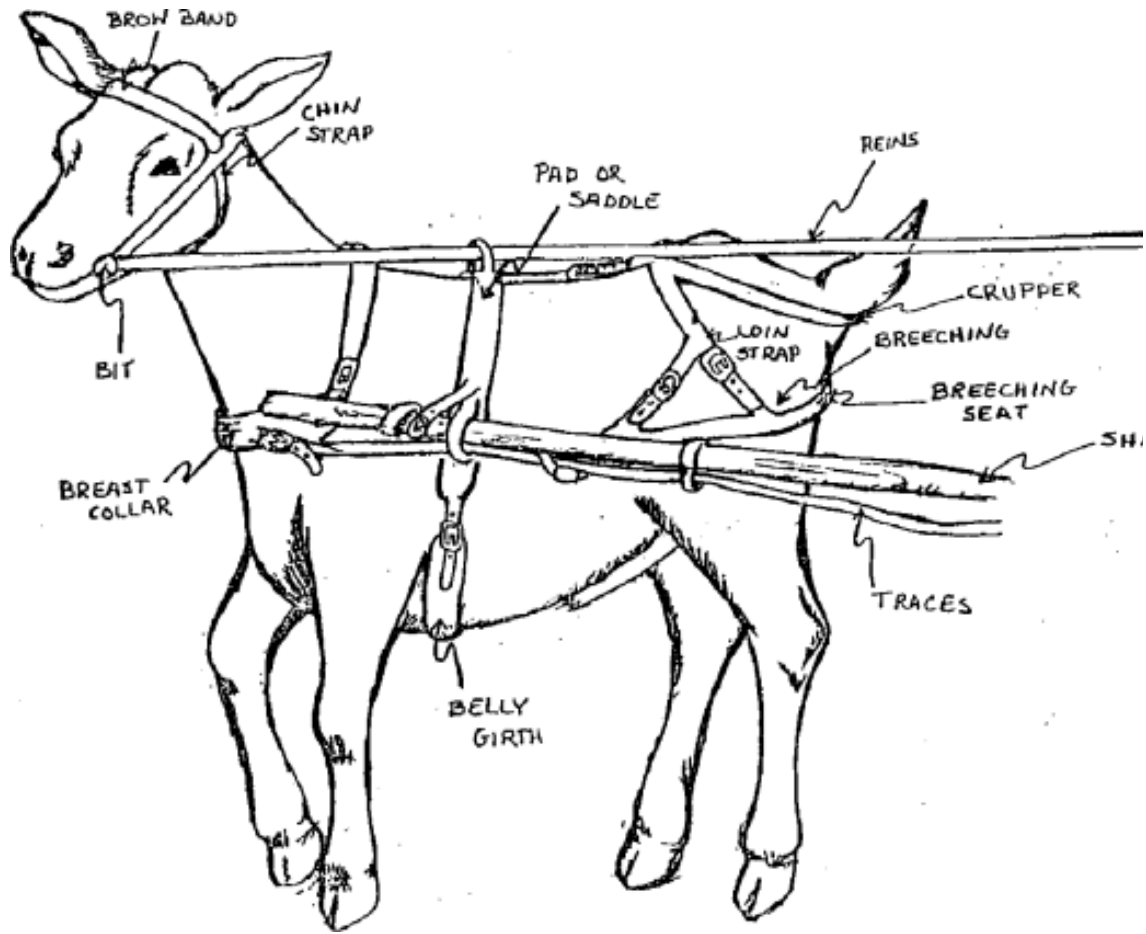

Blind
Bridle

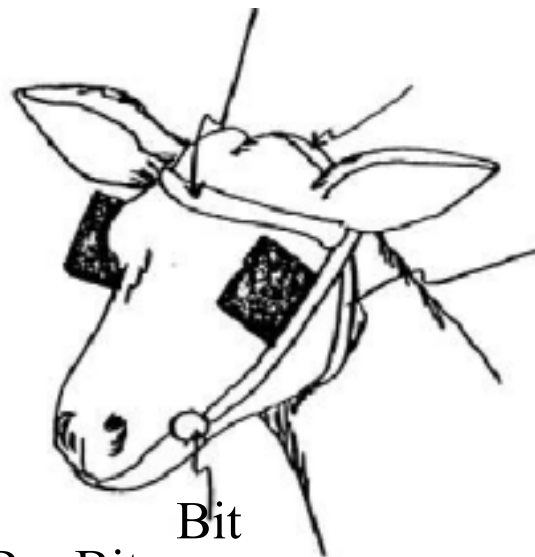

Chin
Strap

Bit

Bar Bit



Snaffle Bit



Double Hitch

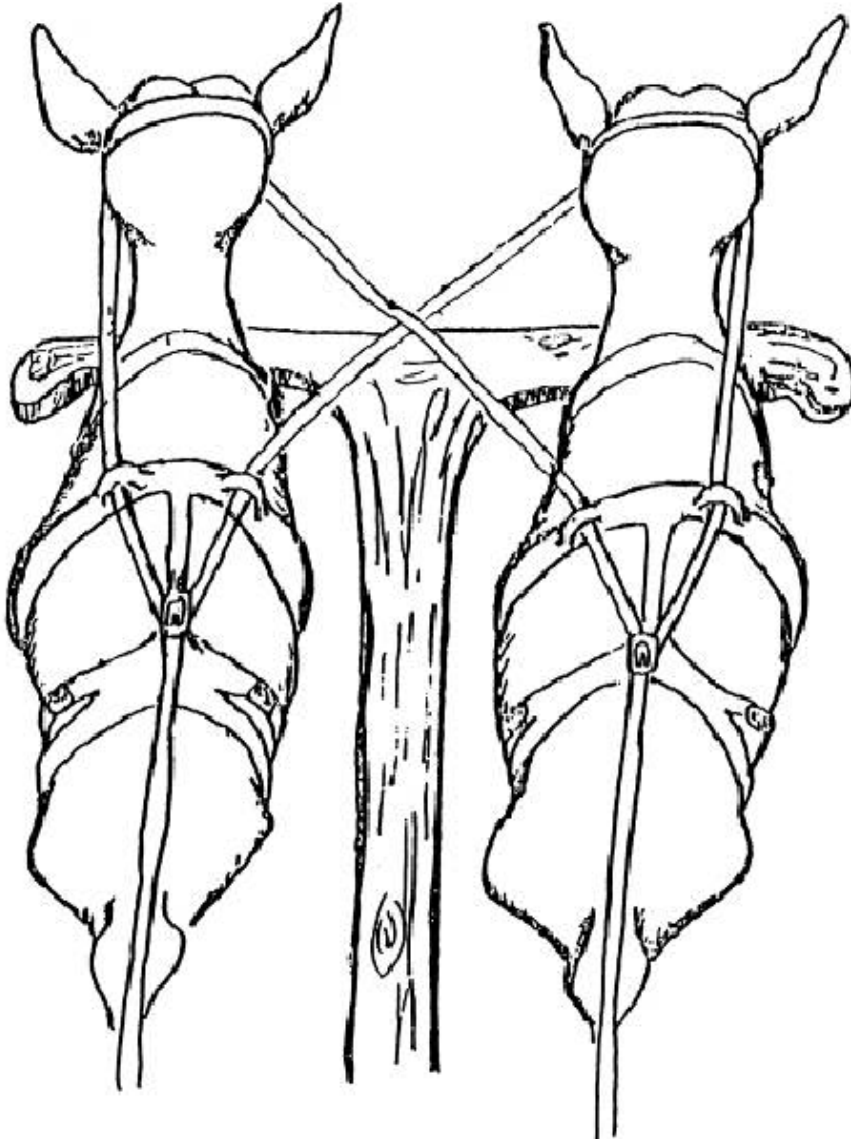

This information is for educational purposes. Reference to commercial products or services is made the understanding that no discrimination is intended and no endorsement is implied in the exclusion of other acceptable products or services

Programs and activities conducted by the Cooperative Extension Services of Michigan, Ohio and New York are available to all potential clientele without regard to race, color, sex, religion, religious creed, ancestry or national origin, age, political belief, veteran status, sexual orientation, marital or family status, disability or physical or mental disability.